



The new degree of comfort.®

## Professional **Classic**® electric short (lowboy) with side water connections water heaters are engineered for longer life – resitorded heating elements and premium grade anode rod

### Efficiency

- .92 - .94 UEF
- Isolated tank design reduces conductive heat loss
- Resitorded stainless steel upper and lower heating elements to prolong anode rod and tank life

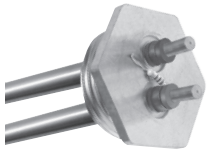

### Performance

- FHR: 48 - 59 gallons, based on gallon capacity
- Recovery: Up to 28 GPH at a 90° F rise, depending on model†

### Longer Life

- Premium grade anode rod provides long-lasting tank protection

### Features

- Electric junction box located above heating elements for easy installation
- Over-temperature protector cuts off power in excess temperature situations
- Automatic thermostat keeps water at desired temperature
- Side water connections convenient for vertically constrained spaces

### Plus...

- Rheemglas® tank lining resists corrosion and prolongs tank life
- EverKleen® device reduces sediment improving efficiency and tank life

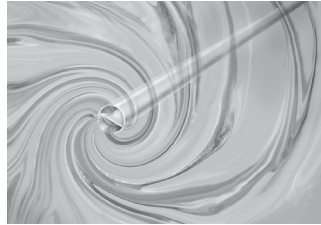

- Enhanced-flow brass drain valve
- Temperature and pressure relief valve included
- Models are compliant to HUD Standards for manufactured housing and modular construction
- Low lead compliant

### Warranty

- 6-Year limited tank and parts warranty\*

\*See Residential Warranty Certificate for complete information

Units meet or exceed ANSI requirements and have been tested according to the AHRI Operations Manual and D.O.E. procedures. Units meet or exceed the energy efficiency requirements of NAECA, ASHRAE standard 90, ICC Code and all state energy efficiency performance criteria.



### Professional **Classic** Electric with Side Water Connections

30 and 40-Gallon Capacities  
240 Volt AC/Single Phase  
Double Element, Blanketed Models  
Electric



See specifications chart on back.





The new degree of comfort.®



# Specifications

TYPE	DESCRIPTION			FEATURES			ROUGHING IN DIMENSIONS (SHOWN IN INCHES)						ENERGY INFO.
	NOMINAL GALLON CAPACITY	RATED GALLON CAPACITY	MODEL NUMBER	WATTAGE	FIRST HOUR RATING (GALLONS)	RECOVERY IN G.P.H. 90° F RISE	TANK HEIGHT A	HEIGHT TO INLET B	HEIGHT TO OUTLET C	HEIGHT TO RELIEF VALVE D	DIAMETER	APPROX. SHIP WT. (LBS.)	
Short	28	26	PROE28 S2 RH93 SB	4500	48	21	30	7-1/8	22-3/8	22-3/8	19-3/4	97	0.92
Short	28	26	PROE28 S2 RH93 SB-HO	5500	53	25	30	7-1/8	22-3/8	22-3/8	19-3/4	97	0.94
Short	38	35	PROE38 S2 RH93 SB	4500	55	28	31-1/2	6-7/8	23-1/4	24-3/8	23	128	0.93
Short	38	35	PROE38 S2 RH93 SB	5500	56	28	31-1/2	6-7/8	23-1/4	24-3/8	23	128	0.93
Short	38	35	PROE38 S2 RH93 SB	6000	59	28	31-1/2	6-7/8	23-1/4	24-3/8	23	128	0.94

Uniform Energy Factor and rated gallon capacity based on Department of Energy (DOE) requirements. Insulation blanket required to meet UEF Value. Water heater dimensions prior to installing insulation blanket that is included with water heater. The blanket adds 2-1/2 inches to tank height and 4 inches to tank diameter.

- If heating elements of different wattages than those shown are demanded by zone requirements, they must be specifically requested.
- All models equipped with heat traps.

$${}^1\text{Recovery} = \frac{\text{wattage}}{2.42} \times \text{temp. rise } ^\circ\text{F.}$$

Example:  $\frac{4500\text{W}}{2.42 \times 90^\circ} = 21 \text{ GPH}$

$${}^1\text{Recovery} = \frac{\text{wattage}}{2.42} \times \text{temp. rise } ^\circ\text{F.}$$

Example:  $\frac{5500\text{W}}{2.42 \times 90^\circ} = 25 \text{ GPH}$

$${}^1\text{Recovery} = \frac{\text{wattage}}{2.42} \times \text{temp. rise } ^\circ\text{F.}$$

Example:  $\frac{6000\text{W}}{2.42 \times 90^\circ} = 28 \text{ GPH}$

<sup>1</sup>Recovery calculations used are based on elements used in non-simultaneous operation

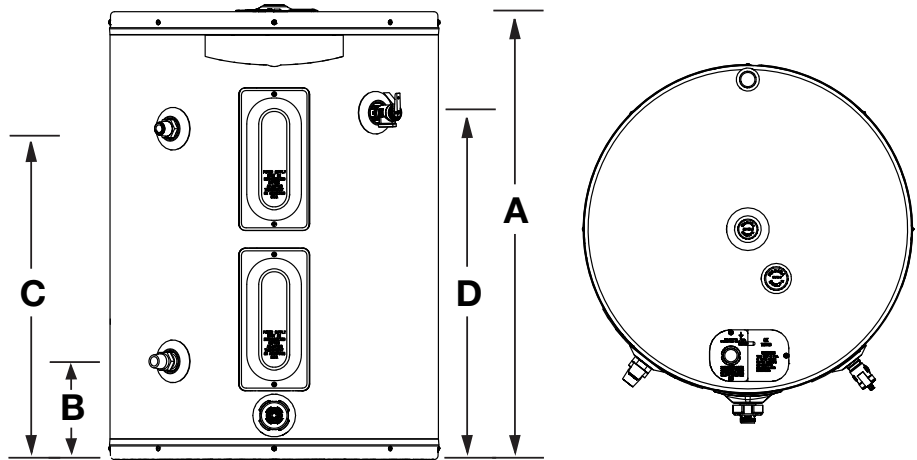

In keeping with its policy of continuous progress and product improvement, Rheem reserves the right to make changes without notice.

Rheem Water Heating • 1115 Northmeadow Parkway, Suite 100  
Roswell, Georgia 30076 • www.rheem.com

