



# Floating Air™ | CLASSIC PLUS® Series Ductless Mini-Split Systems

WALL-MOUNTED, SINGLE ZONE HEAT PUMPS

PURCHASER	P.O. #	DATE
PROJECT	LOCATION	
ENGINEER	ARCHITECT	
SUBMITTED BY	FOR APPROVAL	FOR REFERENCE

ITEM	PLAN DESIGNATION	QUANTITY	COOLING BTU/H	VOLTAGE	RHEEM MODEL

## Key Features

Indicates sustainability feature

- **FastPro®** design for the fastest access for maintenance of any wall-mounted ductless systems
- Precision Inverter®** technology (variable speed compressor)
- Soft-Start™ compressor
- BLDC motor
- Built-in Wi-Fi
- Sleep mode
- All ENERGY STAR® certified models
- All ENERGY STAR® Cold-Climate Heat Pump certified models
  - Ultra quiet operation
  - Easy-to-read temperature display
- Low ambient heat pump operation down to -13
- Low ambient cooling operation down to 5°F
- Wireless remote

FEATURING **FastPro** DESIGN

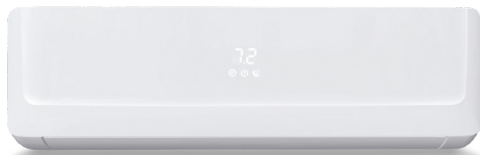

- Efficiencies of up to 25.0 SEER2
- Efficiencies of up to 11.0 HSPF2

**115V:** FAHSW09A1C, FAHSW12A1C

**230V:** FAHFW09A3D, FAHFW12A3D, FAHFW18A3D, FAHFW24A3D

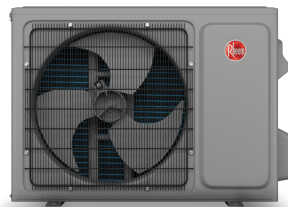

FPHSR09A1C, FPHSR12A1C,  
FPHSR09A3D, FPHSR12A3D

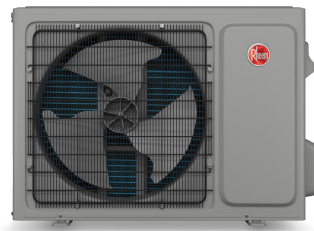

FPHSR18A3D

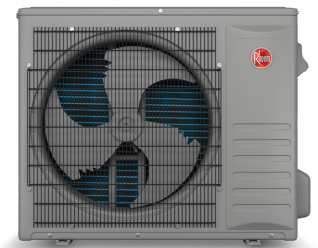

FPHSR24A3D



# FLOATING AIR™ CLASSIC PLUS® SERIES | SINGLE-ZONE | WALL-MOUNTED HEAT PUMPS

MODEL	Model Set	Unit	FPHW091C	FPHW121C	FPHW093D	FPHW123D	FPHW183D	FPHW243D
	Indoor Model		FAHSW09A1C	FAHSW12A1C	FAHFW09A3D	FAHFW12A3D	FAHFW18A3D	FAHFW24A3D
	Outdoor Model		FPHSR09A1C	FPHSR12A1C	FPHSR09A3D	FPHSR12A3D	FPHSR18A3D	FPHSR24A3D
	Power Supply	V/Hz/ph	115V~,60Hz,1P			208V/230V~,60Hz,1P		
	ENERGY STAR® Standard	Y/N	Y	Y	Y	Y	Y	Y
	ENERGY STAR® - Cold Climate	Y/N	Y	Y	Y	Y	Y	Y
COOLING	Rated Capacity @ 95°F	Btu/h	9,000	12,000	9,000	12,000	18,000	24,000
	Cooling Capacity Range (Min.-Max.)	Btu/h	3,600-10,000	4,000-13,000	3,600-10,000	4,000-13,000	6,500-19,000	8,000-25,000
	EER2 @ 95°F	Btu/h/W	12.25	12.25	13.65	12.25	12.95	12.25
	SEER2	Btu/h/W	23.00	22.00	25.00	23.00	21.00	22.50
	Cooling Operating Range	°F	5°F-118°F	5°F-118°F	5°F-118°F	5°F-118°F	5°F-118°F	5°F-118°F
HEATING	Rated Capacity @ 47°F	Btu/h	9,500	12,000	9,000	12,000	18,000	24,000
	Heating Capacity Range (Min.-Max.)	Btu/h	3,600-10,000	4,000-13,000	3,600-10,000	4,000-13,000	6,500-19,000	8,000-25,000
	COP2 @ 47°F	W/W	3.98 1.90	3.98	4.00 2.10	3.80 2.00	3.70	3.60 1.80
	COP @ 5°F	W/W	10.00 9,500	1.90 9.50	11.00 9,000	10.00 10,800	1.90	9.50 22,000
	HSPF2	Btu/h/W	8,700 4,600	9,300 9,200	9,000 5,400	11,000 6,100	10.00	19,800
	Rated Capacity Heating @ 17°F (-8.3°C)	Btu/h		5,900		-13°F-75°F	18,000	12,100
	Maximum Heating Capacity @ 5°F (-15°C)	Btu/h					18,000	-13°F-75°F
	Maximum Heating Capacity @ -13F (-25°C) Heating Operating Range	Btu/h					11,500	
		°F		-13°F-75°F		-13°F-75°F		-13°F-75°F
INDOOR AIRFLOW	Air Circulation (Max/H/M/L)	ft3 CFM	382/341/294/247	394/365/312/253	382/341/294/247	394/365/312/253	647/588/482/382	706/647/559/441
	Sound Rating - Indoor (Max/H/M/L/Quiet)	dB (A)	42/39/37/35/32	42/39/37/35/32	42/39/37/35/32	42/39/37/35/32	48/45/41/39/36	50/48/43/41/39
INDOOR FAN MOTOR	Output	W	46	46	25	25	35	35
	Speed (Hi/Med/Lo)	r/min	1100/940/800	1154/992/800	1101/938/800	1154/992/800	1100/960/800	1200/1040/880
OUTDOOR AIRFLOW	Air Circulation (Hi) for Outdoor	ft3 CFM	1,471	1,471	1,471	1,471	1,942	2,531
	Sound Rating - Outdoor	dB (A)	53.0	53.0	53.0	53.0	58.0	61.0
FAN MOTOR	(Hi) Output	W	36	36	36	36	60	102
	Speed (Hi)	r/min	850	880	880	880	840	880
ELECTRICAL	Rated Current	Cooling (A)	6.0	6.0	2.5	4.3	6.1	8.7
		Cooling (W)	641	980	659	980	1,390	1,959
		Heating (A)	6.4	6.4	3.1	4.1	6.5	9.3
		Heating (W)	696	960	659	926	1,426	1,954
	MOP (Rating of Overcurrent Protective Device)	A	25	25	15	15	30	35
	MCA (Minimum Circuit Ampacity)	A	16.0	16.0	9.5	10.5	20.0	22.0
Communication Wire Size and Type		4 x 18AWG	4 x 18AWG	4 x 18AWG	4 x 18AWG	4 x 18AWG	4 x 18AWG	
REFRIGERATION (R454B)	Moisture Removal	pints/hr	1.9	2.5	1.9	2.5	3.2	4.7
	Refrigerant Charge Volume	oz.	33.5	35.3	35.3	38.1	53.0	70.6
	Liquid Pipe	in.	1/4	1/4	1/4	1/4	1/4	3/8
	Gas Pipe	in.	3/8	3/8	3/8	3/8	1/2	5/8
	Max. Pipe Length (Total)	ft.	65.6	65.6	65.6	65.6	98.4	98.4
	Max. Elevation (Indoor Units Higher Than Outdoor Unit)	ft.	49.2	49.2	49.2	49.2	49.2	49.2
	Pre-charge Pipe Length	ft.	24.6	24.6	24.6	24.6	24.6	24.6
	Additional Refrigerant Charge per Foot after 25 ft.	oz./ft.	0.22	0.22	0.22	0.22	0.22	0.32
INDOOR UNIT	Dimension (W×H×D)	in.	33 7/8 × 11 2/8 × 8 4/8	33 7/8 × 11 2/8 × 8 4/8	33 7/8 × 11 2/8 × 8 4/8	33 7/8 × 11 2/8 × 8 4/8	45 2/8 × 13 2/8 × 10 1/8	45 2/8 × 13 2/8 × 10 1/8
		mm	860×285×216	860×285×216	860×285×216	860×285×216	1,148×336×256	1,148×336×256
	Packing (LxHxW)	in.	36 5/8 × 15 × 11 2/8	36 5/8 × 15 × 11 2/8	36 5/8 × 15 × 11 2/8	36 5/8 × 15 × 11 2/8	47 7/8 × 16 1/8 × 13	47 7/8 × 16 1/8 × 13
		mm	930×380×285	930×380×285	930×380×285	930×380×285	1,215×410×330	1,425×460×395
	Net Weight	lbs.	22.1	22.05	22.1	22.05	34.2	34.2
		kg	10.0	10.0	10.0	10.0	16.0	16.0
Shipping Weight	lbs.	26.5	26.5	26.5	26.5	39.7	39.7	
	kg	12.0	12.0	12.0	12.0	18.0	18.0	
OUTDOOR UNIT	Dimension (W×H×D)	in.	31 7/8 × 23 × 11	31 7/8 × 23 × 11	31 7/8 × 23 × 11	31 7/8 × 23 × 11	33 7/8 × 25 5/8 × 12 2/8	35 3/8 × 29 4/8 × 13 3/8
		mm	810×585×280	810×585×280	810×585×280	810×585×280 37	860×650×310 39 1/8	900×750×340
	Packing (L×H×W)	in.	37 × 24 6/8 × 15 1/8	37 × 24 6/8 × 15 1/8	37 × 24 6/8 × 15 1/8	× 24 6/8 × 15 1/8	× 28 3/8 × 16 4/8	41 6/8 × 32 2/8 × 17 6/8
		mm	940×630×385	940×630×385	940×630×385	940×630×385	995×720×420	1,060×820×450
	Net Weight	lbs.	75.0	77.2	70.6	70.6	97.0	112.5
		kg	34.0	35.0	32.0	32.0	44.0	51.0
Shipping Weight	lbs.	86.0	86.0	81.6	81.6	105.8	121.3	
	kg	39.0	39.0	37.0	37.0	48.0	55.0	

Due to continuing research in new energy-saving technology, specifications are subject to change without notice.



**DIMENSIONAL DRAWINGS : WALL-MOUNTED HEAT PUMPS**  
 INDOOR UNIT / FAHSW09A1C, FAHFW09A3D FAHSW12A1C, FAHFW12A3D

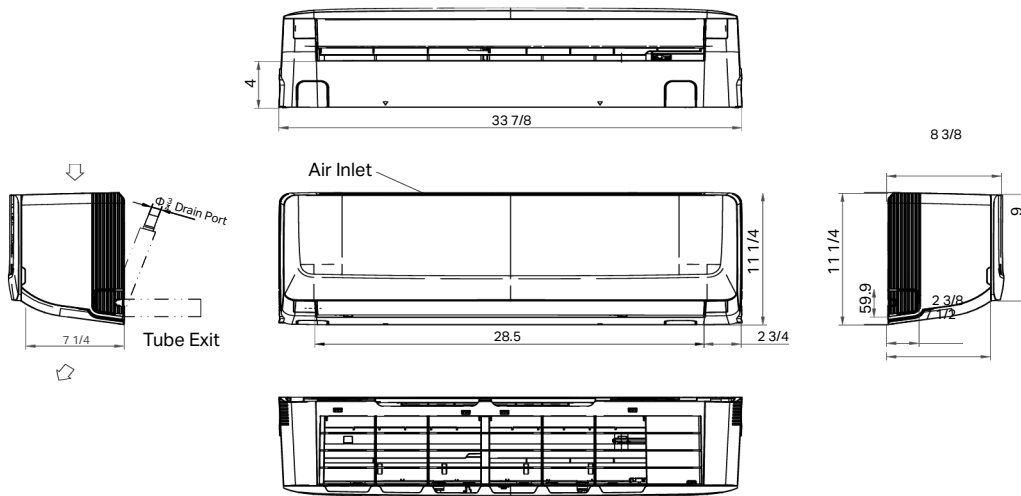

Model	W	H	D
FAHSW09A1C, FAHFW09A3D FAHSW12A1C, FAHFW12A3D	33 7/8"	11 2/8"	8 4/8"

UNITS: INCHES

INDOOR UNIT / FAHFW18A3D, FAHFW24A3D

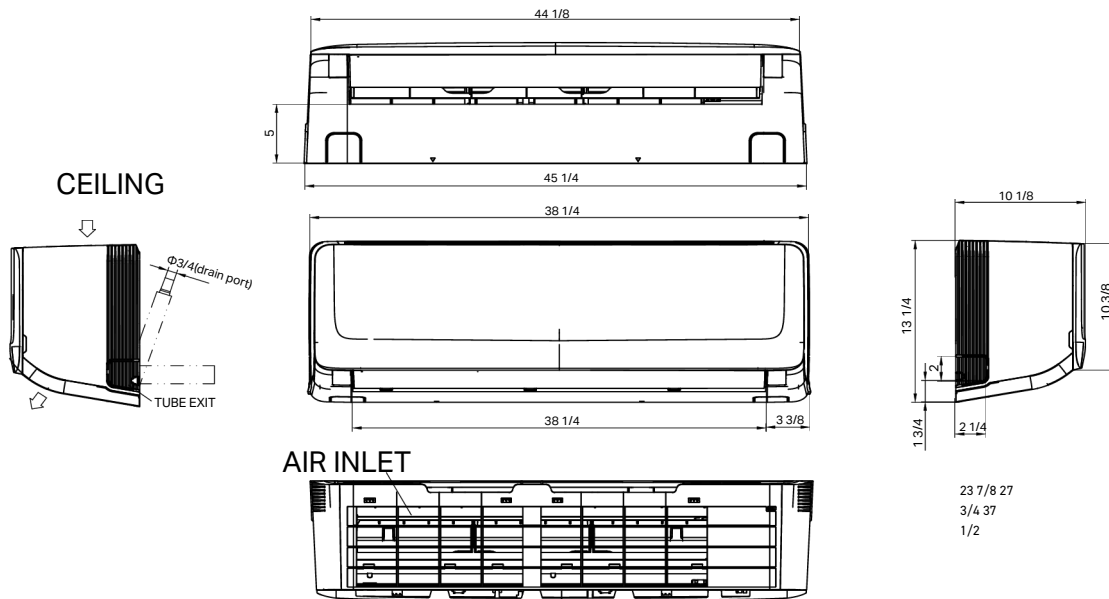

Model	W	H	D
FAHFW18A3D, FAHFW24A3D	45 2/8"	13 2/8"	10 1/8"

UNITS: INCHES

# DIMENSIONAL DRAWINGS OUTDOOR HEAT PUMPS

OUTDOOR UNITS / FPHSR09A1C, FPHSR09A3D, FPHSR12A1C, FPHSR12A3D

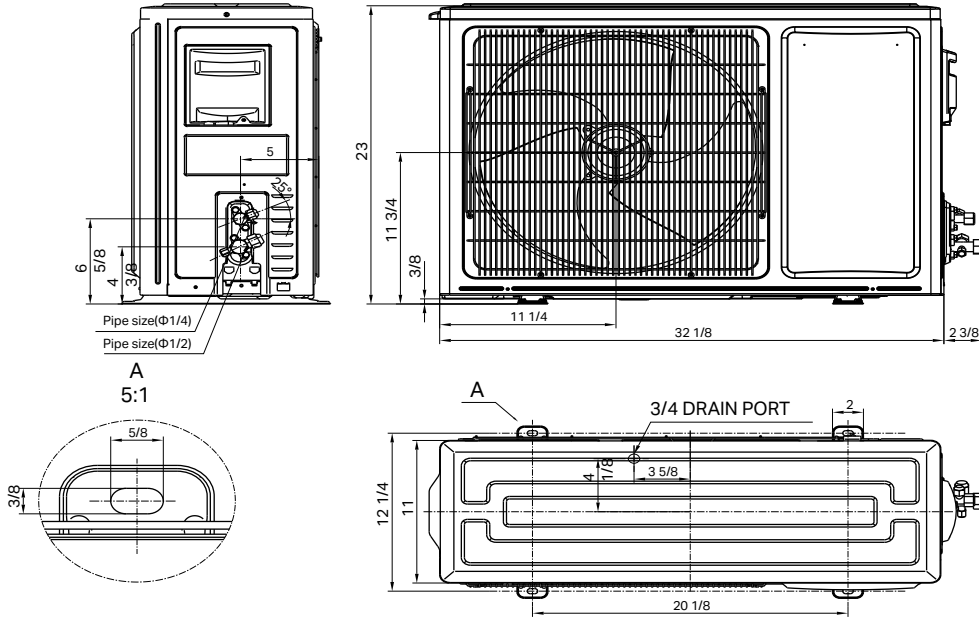

UNITS: INCHES

Model	W	H	D
FPHSR09A1C, FPHSR09A3D	31 7/8"	23"	11"
FPHSR12A1C, FPHSR12A3D			

# DIMENSIONAL DRAWINGS: OUTDOOR HEAT PUMPS

## OUTDOOR UNITS / FPHSR18A3D

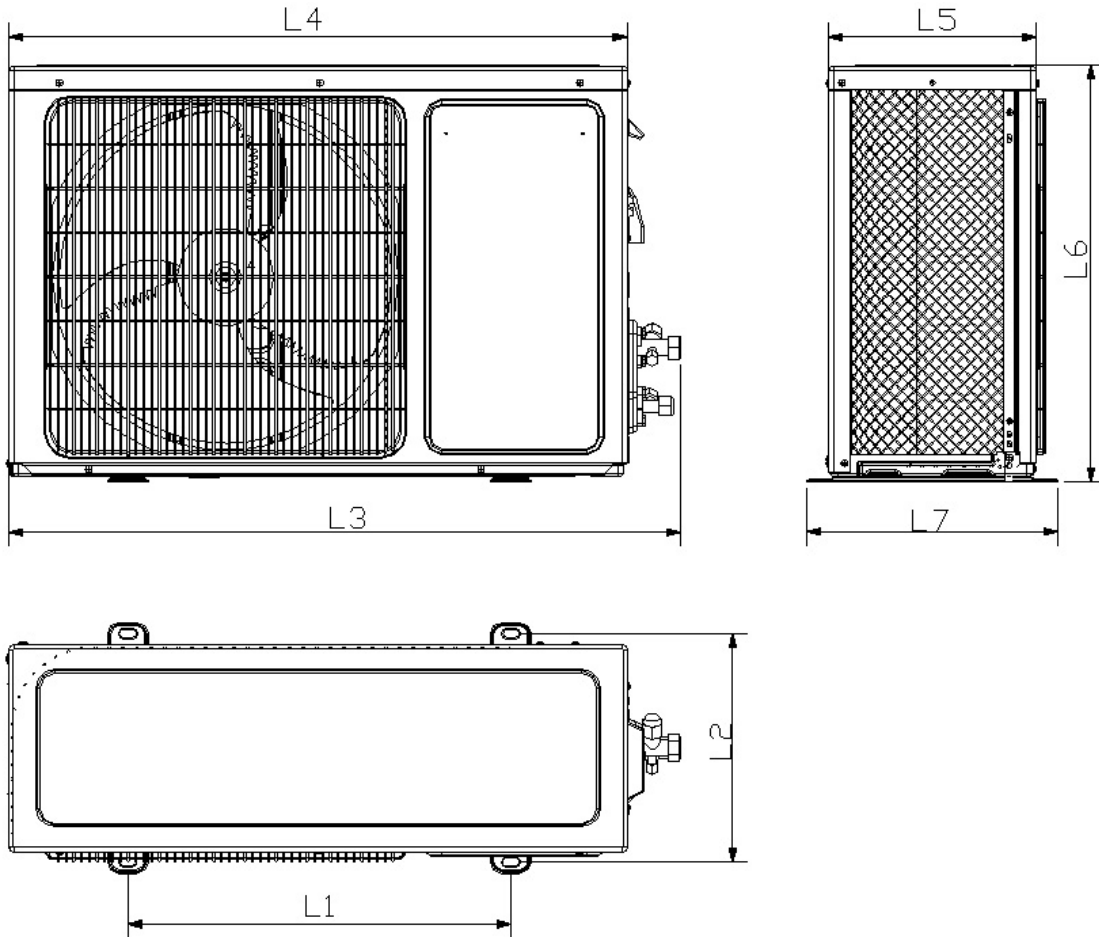

				Width	Depth	Height	
Model	L1 (in.)	L2 (in.)	L3 (in.)	L4 (in.)	L5 (in.)	L6 (in.)	L7 (in.)
<b>FPHSR18A3D</b>	21 11/32	12 19/32	34 7/8	33 7/8	12 1/8	25 1/2	13

UNITS: INCHES

# DIMENSIONAL DRAWINGS: OUTDOOR HEAT PUMPS

## OUTDOOR UNITS / FPHSR24A3D

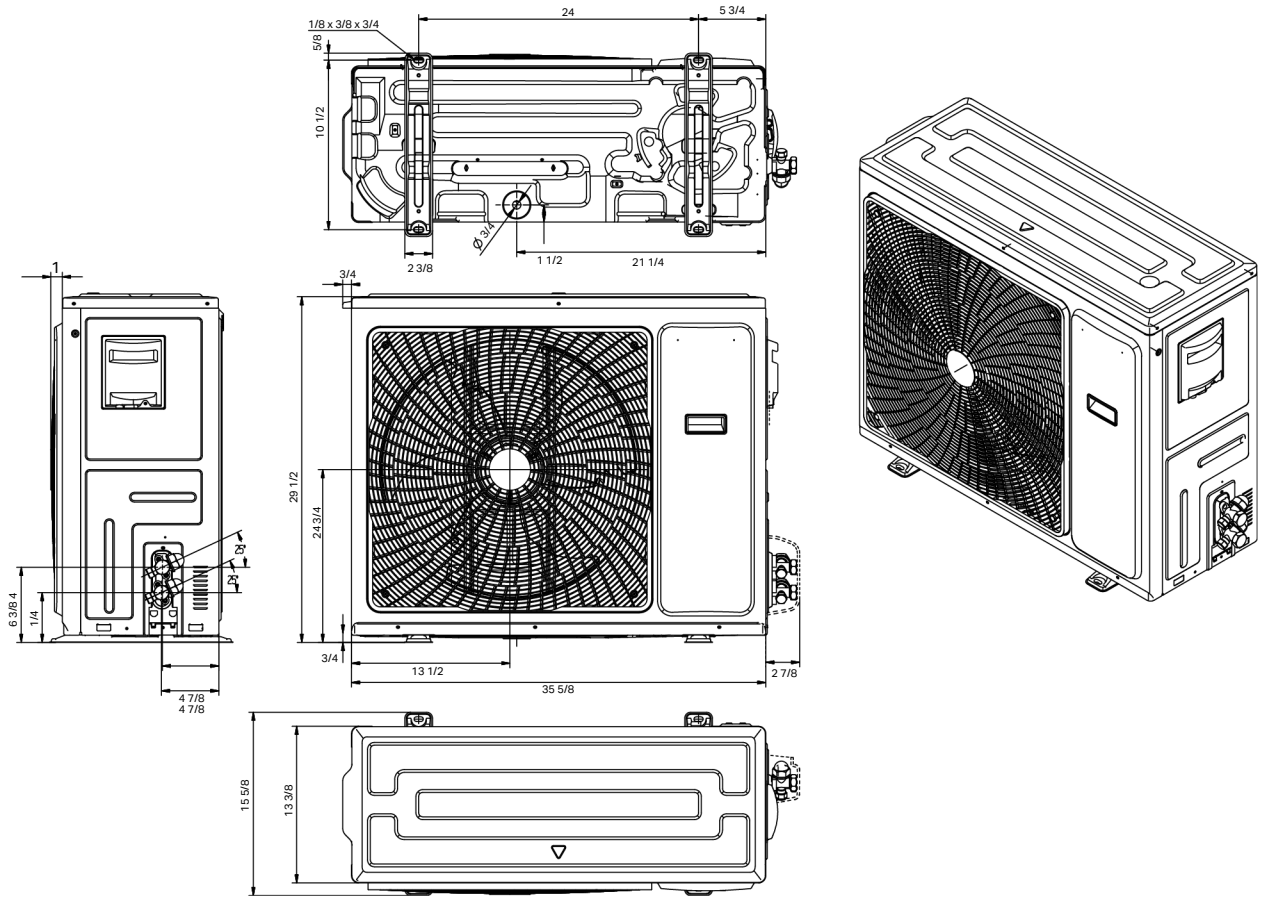

Model	W	H	D
<b>FPHSR24A3D</b>	35 3/8"	29 4/8"	13 3/8"

UNITS: INCHES

## REFRIGERATION LINE SETS\*

Kit#	Length (ft.)	Liquid	Suction	System Model
T32150	15'	1/4"	3/8"	FPHW091C, FPHW121C, FPHW093D, FPHW123D
T32350	35'	1/4"	3/8"	

Kit#	Length (ft.)	Liquid	Suction	System Model
T42150	15'	1/4"	1/2"	FPHW183D
T53250	25'	3/8"	5/8"	FPHW243D

\*Insulated line sets are available for all Rheem split systems in 15 ft. and 35 ft. lengths. Each line set is equipped with flare nuts on both ends. Both liquid and suction lines are insulated. Line sets can be joined together with field supplied double male connectors. Each system requires one line set for each indoor unit installed.

### REFRIGERATION LINE SETS MIN./MAX. LENGTHS

System Model	Min. (ft.)	Max. (ft.)
FPHW091C, FPHW121C, FPHW093D, FPHW123D	10	66
FPHW183D	10	98
FPHW243D	15	98

### TORQUE WRENCH SETTINGS

Outside Diameter		Torque	
mm	inch	ft-lbs.	N-m
6.35	1/4	13 – 18	17.6 – 24.5
9.52	3/8	25 – 30	33.3 – 41.2
12.7	1/2	40 – 47	53.9 – 64.7
15.88	5/8	45 – 59	61.7 – 80.4

## ACCESSORIES



**FPWC1** – Optional hard-wired controller for Floating Air wall-mounted and cassette indoor models. Included with concealed ducted models. Not compatible with AHU indoor models. See your Rheem representative for options.



**DSSXEMWRTA4** – Optional wireless energy management thermostat with occupancy sensor. For Floating Air *Classic Plus*® Series, single- and multi-zone models.



**ADS01** – Optional A2L sensor for Floating Air FAHMMW07A3D, FAHFW09A3D, and FAHFW12A3D 230V indoor wall-mounted. See Installation and Operational Manual for additional information & requirements.



**FreshAire Purifier APWM1 by iWave®** – Optional accessory for all wall-mounted ductless models that kills mold, bacteria and viruses—while effectively removing odors and VOCs.