



Floating Air™ | PRESTIGE®

Ductless Mini-Split Systems

WALL-MOUNTED, CEILING CASSETTE, CONCEALED DUCTED, AIR HANDLER

PURCHASER	P.O. #	DATE
PROJECT	LOCATION	
ENGINEER	ARCHITECT	
SUBMITTED BY	FOR APPROVAL	FOR REFERENCE

ITEM	PLAN DESIGNATION	QUANTITY	COOLING BTU/H	VOLTAGE	RHEEM MODEL

Multi-Zone Outdoor Heat Pump Key Features

Indicates sustainability feature

- Precision Inverter® technology (variable speed compressor)
- Soft-Start™ compressor
- BLDC motor
- All ENERGY STAR® certified models
- All ENERGY STAR® Cold-Climate Heat Pump certified models
- Extreme cold climate heat pump performance: 100% of rated capacity at 5°F*

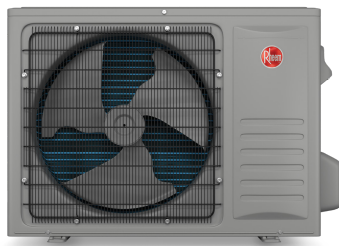

FPHMR18A3D

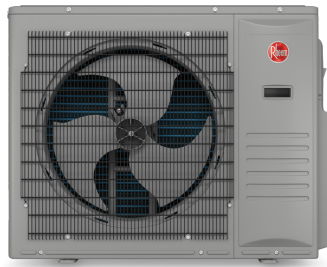

FPHMR27A3D, FPHMR36A3D,
FPHMR42A3D



- Low ambient heat pump operation down to -13°F
- Low ambient cooling operation down to 5°F
- Low temperature compressor start-up protection

*Multi-zone 42K BTU models operate at 86% capacity at 5°F.



FLOATING AIR™ PRESTIGE® | MULTI-ZONE | OUTDOOR HEAT PUMPS

MODEL	Outdoor Model	Unit	FPHMR18A3D	FPHMR27A3D	FPHMR36A3D	FPHMR42A3D
	Power Supply	V/Hz/ph	208V/230V~,60Hz,1P			
ENERGY STAR® Standard*	Y/N	Y	Y	Y	Y	
ENERGY STAR – Cold Climate*	Y/N	Y	Y	Y	Y	
COOLING	Rated Capacity @ 95°F	Btu/h	18,000	27,000	36,000	42,000
	Cooling Capacity Range (Min.-Max.)	Btu/h	9,000-22,000	9,000-31,000	9,000-46,800	9,000-54,600
	EER2 @ 95°F*	Btu/h/W	13.30	12.85	12.85	12.00
	SEER2	Btu/h/W	22.00	23.00	22.00	22.00
	Cooling Operating Range	°F	5°F-125°F	5°F-125°F	5°F-125°F	5°F-125°F
HEATING	Rated Capacity @ 47°F	Btu/h	18,000	27,000	36,000	48,000
	Heating Capacity Range (Min.-Max.)	Btu/h	9,000-30,000	9,000-44,000	9,000-54,000	9,000-58,000
	COP2 @ 47°F*	W/W	3.82	3.60	3.91	3.60
	COP @ 5°F*	W/W	1.99	1.82	1.92	1.92
	HSPF2*	Btu/h/W	10.00	10.00	10.00	9.50
	Rated Capacity Heating @ 17°F (-8.3°C)	Btu/h	11,500	17,600	22,600	28,200
	Maximum Heating Capacity @ 5°F (-15°C)	Btu/h	18,000	27,000	36,000	36,000
	Maximum Heating Capacity @ -13F (-25°C)	Btu/h	13,356	19,177	26,175	27,216
Heating Operating Range	°F	-13°F-75°F	-13°F-75°F	-13°F-75°F	-13°F-75°F	
OUTDOOR AIRFLOW	Air Circulation (Hi) for Outdoor	ft3 CFM	1,850	3,357	3,357	3,357
	Sound Rating - Outdoor (Hi)	dB (A)	55	62	64	64
FAN MOTOR	Output	W	60	220	220	220
	Speed (Hi)	r/min	880	850	830	830
ELECTRICAL	Rated Current	Cooling (A)	6.3	9.3	12.8	15.5
		Cooling (W)	1350.0	2100.0	2802.0	3500.0
		Heating (A)	6.4	10.0	12.5	18.0
		Heating (W)	1380.0	2200.0	2700.0	3910.0
	MOP (Rating of Overcurrent Protective Device)	A	30.0	40.0	50.0	60.0
	MCA (Minimum Circuit Ampacity)	A	21.0	25.0	32.0	36.0
Communication Wire Size and Type		4 x 14AWG	4 x 14AWG	4 x 14AWG	4 x 14AWG	
REFRIGERATION (R454B)	Moisture Removal	pints/hr	2.4	3.0	4.3	4.4
	Refrigerant Charge Volume	oz.	51.1	76.2	105.8	105.8
	Liquid Pipe	in.	1/4	1/4	1/4	1/4
	Gas Pipe	in.	3/8	3/8	3/8	3/8
	Connection		Flare	Flare	Flare	Flare
	Max. Pipe Length (Total)	ft.	164.0	230.0	230.0	262.0
	Max. Elevation (Indoor Units Higher Than Outdoor Unit)	ft.	49.0	49.0	49.0	49.0
	Pre-charge Pipe Length	ft.	50.0	75.0	100.0	125.0
Additional Refrigerant Charge per Foot after 25 ft.	oz./ft.	0.2	0.2	0.2	0.2	
OUTDOOR UNIT	Dimension (W×H×D)	in. 1/8ths	33 7/8×26 3/8×12 1/4	38 3/8×32 7/8×14 1/8	38 3/8×32 7/8×14 1/8	38 3/8×32 7/8×14 1/8
		mm	860×670×310	975×835×360	975×835×360	975×835×360
	Packing (L×W×H)	in. 1/8ths	39×17 3/4×-28 3/4	43 3/4×18 1/8×37 3/4	43 3/4×18 1/8×37 3/4	43 3/4×18 1/8×37 3/4
		mm	990×450×730	1,111×460×960	1,111×460×960	1,111×460×960
	Net Weight	lbs.	101.4	160.6	169.8	172.0
		kg	46.0	72.9	77.0	78.0
Shipping Weight	lbs.	112.4	183.2	191.8	194	
	kg	51.0	83.1	87.0	88.0	

MULTI-ZONE CONFIGURATION, AHRI RATINGS

Model	AHRI Reference Number	Indoor Type	System Cooling 95°F Capacity	EER2	SEER2	High Heat 47°F	HSPF/ HSPF2	Low Heat 17°F (-8.3°C)	Low Heat 5°F (-15°C)	COP 5°F	Maximum Heating Capacity 5°F (-15°C)
FPHMR18A3D	215792836	Non-Ducted Indoor Units	18,000	13.30	22.00	18,000	10.00	11,500	18,000	1.99	18,000
	215792837	Ducted Indoor Units	18,000	12.00	17.50	18,000	9.40	11,900	17,000	1.96	18,000
	215792838	Mixed Ducted and Non-Ducted Indoor Units	18,000	12.65	19.75	18,000	9.70	11,700	17,400	1.96	18,000
FPHMR27A3D	215792839	Non-Ducted Indoor Units	27,000	12.85	23.00	27,000	10.00	17,600	27,000	1.82	27,000
	215792840	Ducted Indoor Units	27,000	11.50	18.00	27,000	8.80	18,200	26,400	1.84	27,000
	215792841	Mixed Ducted and Non-Ducted Indoor Units	27,000	12.20	20.50	27,000	9.40	18,000	26,600	1.82	27,000
FPHMR36A3D	215792846	Non-Ducted Indoor Units	36,000	12.85	22.00	36,000	10.00	22,600	36,000	1.92	36,000
	215792845	Ducted Indoor Units	36,000	12.85	19.00	36,000	9.00	21,000	32,400	1.83	36,000
	215792847	Mixed Ducted and Non-Ducted Indoor Units	36,000	12.85	20.50	36,000	9.50	21,800	34,200	1.87	36,000
FPHMR42A3D	215792843	Non-Ducted Indoor Units	42,000	12.00	22.00	48,000	9.50	28,200	36,000	1.92	36,000
	215792842	Ducted Indoor Units	42,000	11.35	18.00	45,000	8.80	27,400	34,000	1.83	36,000
	215792844	Mixed Ducted and Non-Ducted Indoor Units	42,000	11.80	20.00	46,500	9.15	27,800	35,000	1.87	36,000







Due to continuing research in new energy-saving technology, specifications are subject to change without notice.



FLOATING AIR™ PRESTIGE® | MULTI-ZONE | INDOOR OPTIONS:

Multi-Zone Wall-Mounted Key Features

 Indicates sustainability feature

- **FastPro®** design for the fastest access for maintenance of any wall-mounted ductless systems
-  **Precision Inverter®** technology (variable speed compressor)
-  Soft-Start™ compressor
-  BLDC motor
-  Built-in Wi-Fi
-  Sleep mode
-  All ENERGY STAR® certified models
-  All ENERGY STAR® Cold-Climate Heat Pump certified models
- Easy-to-read temperature display
- Wireless remote



FEATURING **FastPro®** DESIGN



FAHMMW07A3D, FAHFW09A3D,
FAHFW12A3D, FAHFW18A3D,
FAHFW24A3D



FLOATING AIR™ PRESTIGE® | MULTI-ZONE | WALL-MOUNTED

MODEL	Indoor Model	Unit	FAHMMW07A3D	FAHFW09A3D	FAHFW12A3D	FAHFW18A3D	FAHFW24A3D
	Power Supply	V/Hz/ph	208V/230V~, 60Hz, 1P				
COOLING	Rated Capacity @ 95°F	Btu/h	7,000	9,000	12,000	18,000	24,000
	Cooling Capacity Range (Min.-Max.)	Btu/h	3,600-10,000	4,600-12,700	4,600-12,700	7,800-22,000	10,000-28,000
HEATING	Rated Capacity @ 47°F	Btu/h	8,500	9,000	12,000	18,000	24,000
	Heating Capacity Range (Min.-Max.)	Btu/h	3,600-10,000	5,500-16,000	5,500-16,000	7,800-23,000	6,700-30,000
AIRFLOW	Air Circulation (Max/H/M/L)	ft3 CFM	382/341/294/247	382/341/294/247	394/365/312/253	647/588/482/382	706/647/559/441
	Sound Rating - Indoor (Max/H/M/L/Quiet)	dB (A)	42/39/37/35/32	42/39/37/35/32	42/39/37/35/32	48/45/41/39/36	50/48/43/41/39
FAN MOTOR	Output	W	25	25	25	35	35
	Speed (Hi/Med/Lo)	r/min	1101/938/800	1100/938/800	1154/992/800	1100/960/800	1200/1040/880
DIMENSIONS & WEIGHTS	Dimension (W×H×D)	in.	33-7/8×11-2/8×8-4/8	33-7/8×11-2/8×8-4/8	33-7/8×11-2/8×8-4/8	45-2/8×13-2/8×10-1/8	45-2/8×13-2/8×10-1/8
		mm	860×285×216	860×285×216	860×285×216	1,148×336×256	1,148×336×256
	Packing (L×H×W)	in.	36-5/8×15×11-2/8	36-5/8×15×11-2/8	36-5/8×15×11-2/8	47-7/8×16-1/8×13	47-7/8×16-1/8×13
		mm	930×380×285	930×380×285	930×380×285	1,215×410×330	1,215×410×330
	Net Weight	lbs.	22.1	22.1	22.1	34.2	34.2
		kg	10.0	10.0	10.0	15.5	15.5
	Shipping Weight	lbs.	26.5	26.5	26.5	39.7	39.7
		kg	12.0	12.0	12.0	18.0	18.0

Due to continuing research in new energy-saving technology, specifications are subject to change without notice.









Standard With Registration



FLOATING AIR™ PRESTIGE® | MULTI-ZONE | INDOOR OPTIONS:

Multi-Zone Ceiling Cassette Key Features

 Indicates sustainability feature

-  Precision Inverter® technology (variable speed compressor)
-  Soft-Start™ compressor
-  BLDC motor
-  Built-in Wi-Fi
-  Sleep mode
-  All ENERGY STAR® certified models
-  All ENERGY STAR® Cold-Climate Heat Pump certified models
- Wireless remote
- Independent vane control
- 3 fan speeds
- Ultra-quiet turbo fan
- Evaporator frost control
- Clean, modern look



FPFC09A3D, FPFC12A3D



FPFC18A3D, FPFC24A3D, FPFC36A3D



Ceiling Cassette Grilles (Required)



FPCG0912A



FPCG182436A

DECORATIVE GRILLE	
FPCG0912A	FPCG182436A
FITS FPFC09A3D, FPFC12A3D	FITS FPFC18A3D, FPFC24A3D, FPFC36A3D

FLOATING AIR™ PRESTIGE® | MULTI-ZONE | CEILING CASSETTE

MODEL	Indoor Model	Unit	FPFC09A3D	FPFC12A3D	FPFC18A3D	FPFC24A3D
	Power Supply		V/Hz/ph	208V/230V~,60Hz,1P		
COOLING	Rated Capacity @ 95°F	Btu/h	9,000	12,000	18,000	24,000
	Cooling Capacity Range (Min.-Max.)	Btu/h	4,300-14,500	4,300-14,500	7,800-24,000	9,000-30,000
HEATING	Rated Capacity @ 47°F	Btu/h	9,000	12,000	18,000	24,000
	Heating Capacity Range (Min.-Max.)	Btu/h	5,500-18,000	5,500-18,000	8,500-24,000	7,500-34,000
AIRFLOW	Air Circulation (Max/H/M/L)	ft3 CFM	341/341/294/235	341/341/294/235	643/643/554/465	706/706/588/494
	Sound Rating - Indoor (Max/H/M/L/Quiet)	dB (A)	52	52	50	53
FAN MOTOR	Output	W	57	57	75	75
	Speed (Hi/Med/Lo)	r/min	700/600/500	700/600/500	420/3810/320	470/400/340
DIMENSIONS & WEIGHTS	Dimension (W×H×D)	in. 1/8ths	22-1/2×8-1/2×22-1/2	22-1/2×8-1/2×22-1/2	33-1/8×9-1/4×33-1/8	33-1/8×9-1/4×33-1/8
		mm	570×215×570	570×215×570	840×236×840	840×236×840
	Packing (L×W×H)	in. 1/8ths	28-3/4×26-1/4×11-1/2	28-3/4×26-1/4×11-1/2	37-3/8×12-5/8×37-3/8	37-3/8×12-5/8×37-3/8
		mm	730×668×292	730×668×292	950×950×320	950×950×320
	Net Weight	lbs.	34.2	34.2	52.9	52.9
		kg	15.5	15.5	24.0	24.0
Shipping Weight	lbs.	40.8	40.8	63.9	63.9	
	kg	18.5	18.5	29.0	29.0	
INDOOR GRILLE	Dimension (W×H×D)	in.	24-3/8×1-5/8×24-3/8	24-3/8×1-5/8×24-3/8	37-3/8×2×37-3/8	37-3/8×2×37-3/8
		mm	620×40×620	620×40×620	950×50×950	950×50×950
	Packing (L×W×D)	in.	27-1/8×26-3/4×4-1/2	27-1/8×26-3/4×4-1/2	40-1/8×39-3/8×4-1/8	40-1/8×39-3/8×4-1/8
		mm	690×680×115	690×680×115	1,020×1,000×105	1,020×1,000×105
	Net Weight	lbs.	5.7	5.7	14.3	14.3
		kg	2.6	2.6	6.5	6.5
Shipping Weight	lbs.	9.9	9.9	19.8	19.8	
	kg	4.5	4.5	9.0	9.0	





Due to continuing research in new energy-saving technology, specifications are subject to change without notice.



FLOATING AIR™ PRESTIGE® | MULTI-ZONE | INDOOR OPTIONS:

Multi-Zone The Insider® Concealed Ducted Key Features

 Indicates sustainability feature

-  Precision Inverter® technology (variable speed compressor)
-  Soft-Start™ compressor
-  BLDC motor
-  All ENERGY STAR® certified models
-  All ENERGY STAR® Cold-Climate Heat Pump certified models
- Wall controller included (FPWC1)
- Control lock function on controller
- External static pressure range 9K/12K/18K/24K 0-.40 WC (Multi-zone)

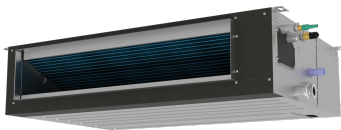

FPHFD09A3D, FPHFD12A3D, FPHFD18A3D, FPHFD24A3D, FPHSD36A3D



FPWC1

FLOATING AIR™ PRESTIGE® | MULTI-ZONE | THE INSIDER® CONCEALED DUCTED

MODEL	Indoor Model	Unit	FPHFD09A3D	FPHFD12A3D	FPHFD18A3D	FPHFD24A3D
	Power Supply	V/Hz/ph	208V/230V~,60Hz,1P			
COOLING	Rated Capacity @ 95°F	Btu/h	9,000	12,000	18,000	24,000
	Cooling Capacity Range (Min.-Max.)	Btu/h	4,300-14,500	4,300-14,500	6,500-25,000	9,000-31,500
HEATING	Rated Capacity @ 47°F	Btu/h	9,000	12,000	18,000	24,000
	Heating Capacity Range (Min.-Max.)	Btu/h	5,300-18,000	5,300-18,000	5,700-30,000	7,600-37,500
AIRFLOW	Air Circulation (Max/H/M/L)	ft3 CFM	324/324/294/235	324/324/294/235	530/530/471/412	735/735/647/559
	Sound Rating - Indoor (Max/H/M/L/Quiet)	dB (A)	57	57	60	68
	ESP (in-H2O)	Rated with filter Range with filter	0.18 0-0.12	0.18 0-0.12	0.18 0-0.56	0.58 0-0.66
FAN MOTOR	Output	W	57	57	75	75
	Speed (Hi/Med/Lo)	r/min	1,110/1,000/800	1,110/1,000/800	920/820/720	1,400/1,250/1,100
DIMENSIONS & WEIGHTS	Dimension (W×H×D)	in.	35-7/8×7-1/2×17-5/8	35-7/8×7-1/2×17-5/8	31-1/2×9-5/8×27-1/2	43-1/4×9-5/8×27-1/2
		mm	910×190×447	910×190×447	800×245×700	1,100×245×700
	Packing (L×W×H)	in.	42-1/2×22-1/4×11-1/4	42-1/2×22-1/4×11-1/4	38-5/8×12-3/8×31-7/8	50-3/8×12-3/8×31-7/8
		mm	1,080×565×285	1,080×565×285	980×315×810	1,280×315×810
	Net Weight	lbs.	44.1	44.1	58.4	73.9
		kg	20.0	20.0	26.5	33.5
Shipping Weight	lbs.	51.8	51.8	58.4	73.9	
	kg	23.5	23.5	31.0	38.5	





Due to continuing research in new energy-saving technology, specifications are subject to change without notice.



FLOATING AIR™ PRESTIGE® | MULTI-ZONE | INDOOR OPTIONS:

Multi-Zone Air Handler Key Features

 Indicates sustainability feature

-  Precision Inverter® technology (variable speed compressor)
-  Soft-Start™ compressor
-  BLDC motor
-  All ENERGY STAR® certified models
-  All ENERGY STAR® Cold-Climate Heat Pump certified models
- Air handler can be installed in 4 configurations; upflow, downflow, horizontal left and horizontal right
- Aluminum indoor coil
- Compatible with 24V thermostats



FPHFA18A3D, FPHFA24A3D

FLOATING AIR™ PRESTIGE® | MULTI-ZONE | AIR HANDLER

MODEL	Indoor Model	Unit	FPHFA18A3D	FPHFA24A3D
		Power Supply	V/Hz/ph	208V/230V~, 60Hz, 1P
COOLING	Rated Capacity @ 95°F	Btu/h	18,000	24,000
	Cooling Capacity Range (Min.-Max.)	Btu/h	10,500-31,000	10,500-31,000
HEATING	Rated Capacity @ 47°F	Btu/h	18,000	24,000
	Heating Capacity Range (Min.-Max.)	Btu/h	11,700-33,000	11,700-33,000
AIRFLOW	Rated Airflow	ft3 CFM	800	800
	Min-Max	ft3 CFM	529-823	529-823
	Sound Rating - Indoor (Hi)	dB (A)	51	51
FAN MOTOR	Output	W	373	373
	RLA	A	2.6	2.6
	Speed (Hi-Lo)	r/min	350-1400	350-1400
DIMENSIONS & WEIGHTS	Dimension (W×H×D)	in.	17-4/8×45×21	17-4/8×45×21
		mm	445×1,143×534	445×1,143×534
	Packing (L×H×W)	in.	20-4/8×25-2/8×49-6/8	20-4/8×25-2/8×49-6/8
		mm	520×1,265×640	520×1,265×640
	Net Weight	lbs.	130.5	130.5
		kg	59.2	59.2
	Shipping Weight	lbs.	153.6	153.6
		kg	69.7	69.7

Due to continuing research in new energy-saving technology, specifications are subject to change without notice.



ACCESSORIES:



FPWC1 – Optional hard-wired controller for Floating Air wall-mounted and cassette indoor models. Included with concealed ducted models. Not compatible with AHU indoor models. See your Rheem representative for options.



DSSXEMWRTA4 – Optional wireless energy management thermostat with occupancy sensor. For Floating Air *Achiever Plus®* Series, single- and multi-zone models.



ADS01 – Optional A2L sensor for Floating Air FAHMR07A3D, FAHFW09A3D, and FAHFW12A3D 230V indoor wall-mounted. See Installation and Operational Manual for additional information & requirements.



FreshAir Purifier APWM1 by iWave® – Optional accessory for all wall-mounted ductless models that kills mold, bacteria and viruses—while effectively removing odors and VOCs.

REFRIGERATION LINE SETS OUTSIDE DIMENSIONS & MIN./MAX. LENGTHS

Model	Liquid	Suction	Lineset Kit	Lineset Kit	Min. (Ft.)	Max. EA./Total (Ft.)
FPHMR18A3D	1/4	3/8	T32150 - 15'	T32350 - 35'	25	82/164
FPHMR27A3D	1/4	3/8	T32150 - 15'	T32350 - 35'	25	66/230
FPHMR36A3D	1/4	3/8	T32150 - 15'	T32350 - 35'	25	66/230
FPHMR42A3D	1/4	3/8	T32150 - 15'	T32350 - 35'	25	66/230

DIMENSIONAL DRAWINGS : CONDENSERS

OUTDOOR UNITS / FPHMR18A3D

UNITS: INCHES (MM)

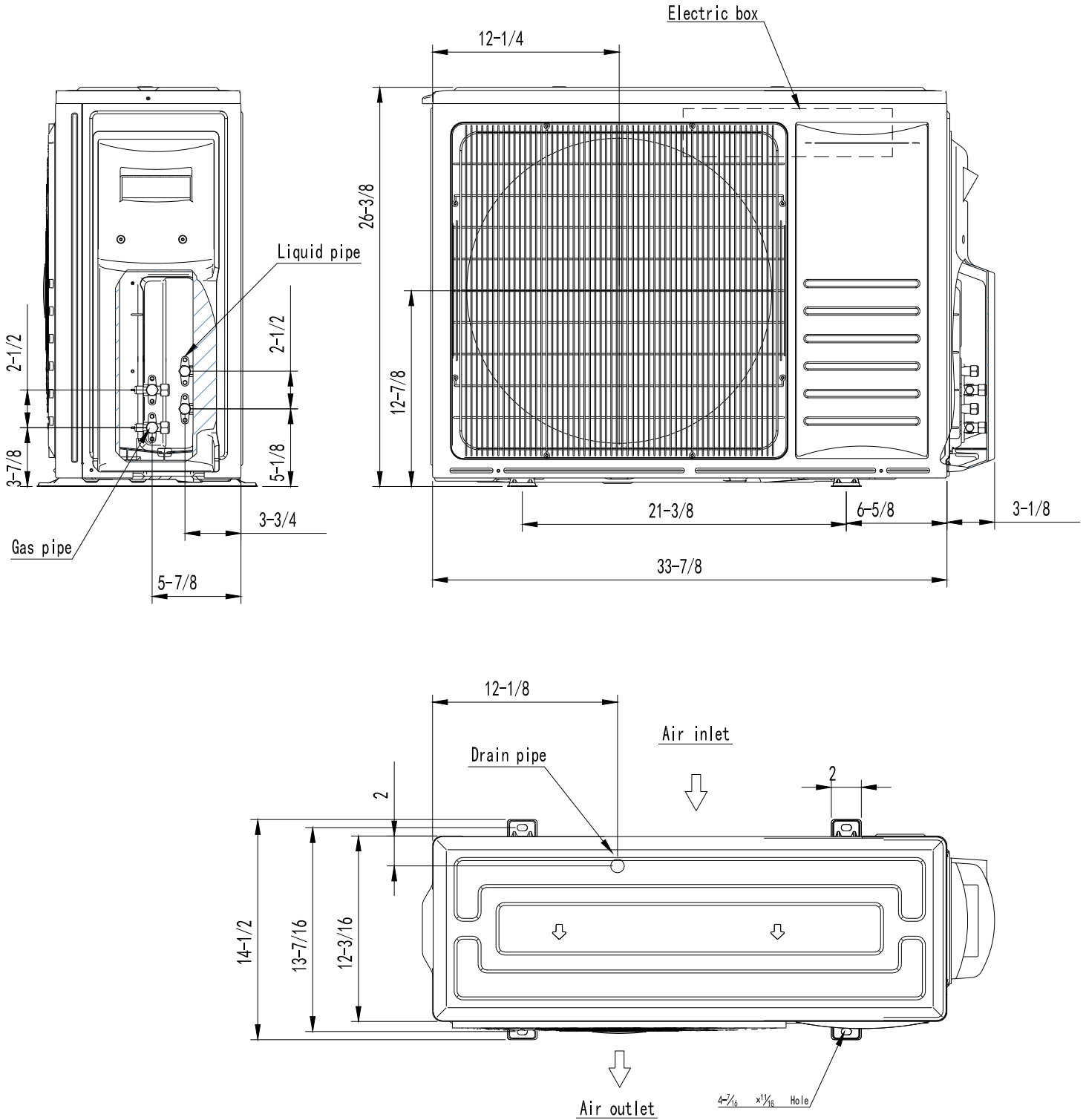

DIMENSIONAL DRAWINGS : CONDENSERS

OUTDOOR UNITS / FPHMR27A3D, FPHMR36A3D, FPHMR42A3D

UNITS: INCHES

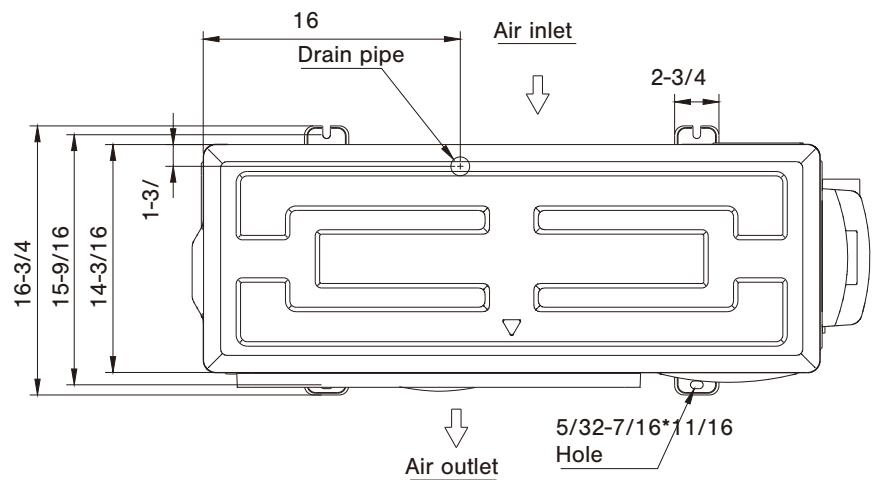
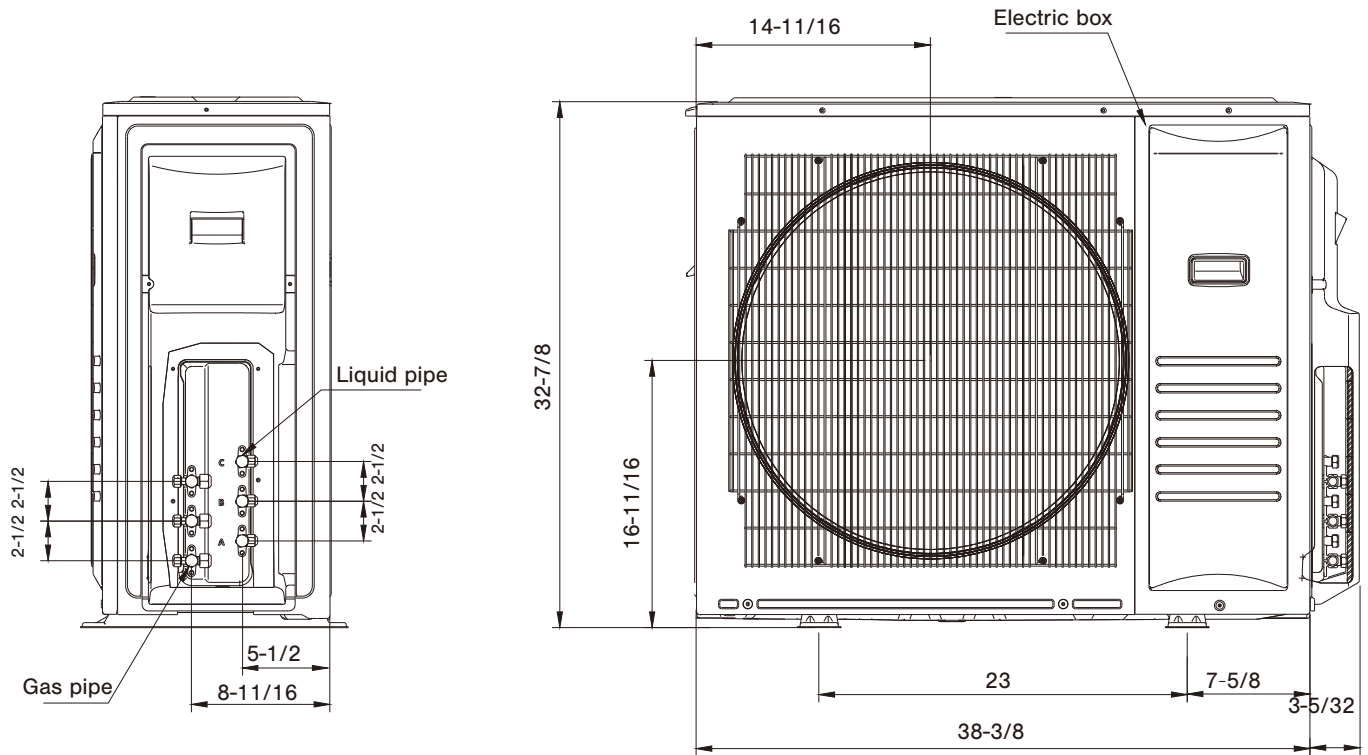

DIMENSIONAL DRAWINGS : WALL-MOUNTED

INDOOR UNITS / FAHFW07A3D, FAHFW09A3D, FAHFW12A3D

UNITS: INCHES

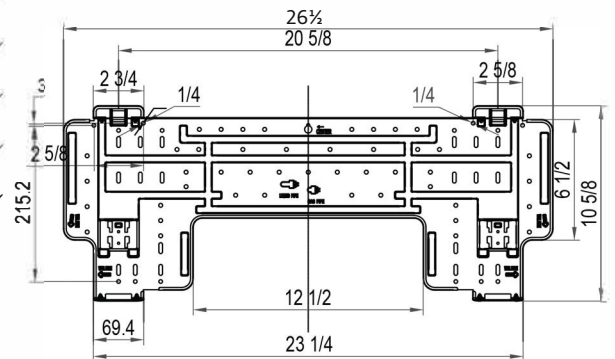
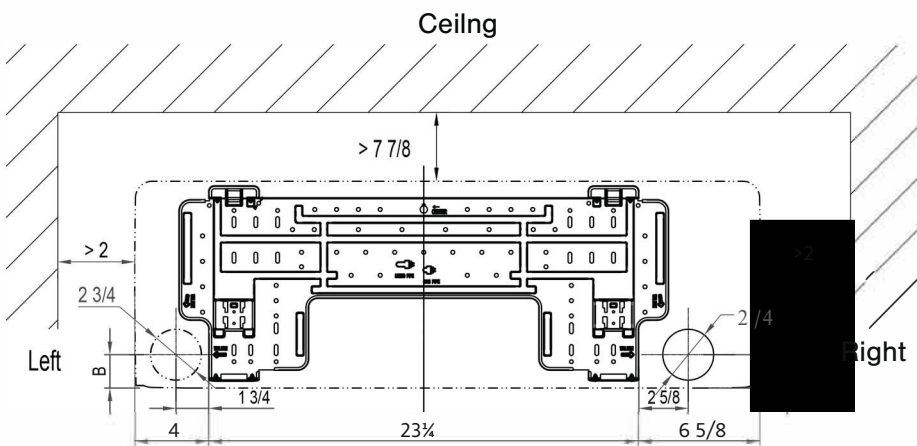
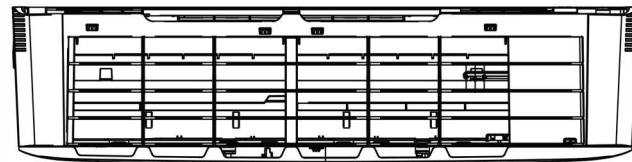
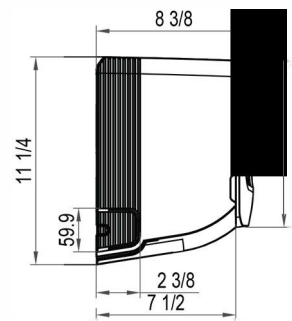
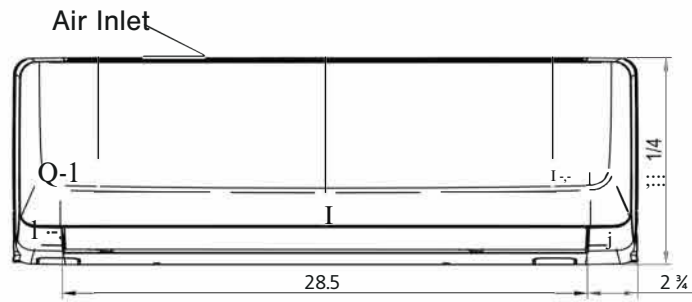
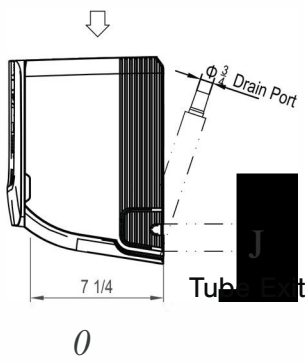
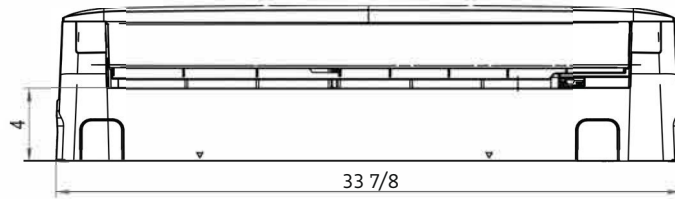

DIMENSIONAL DRAWINGS : WALL-MOUNTED INDOOR UNITS / FAHFW18A3D, FAHFW24A3D

UNITS: INCHES

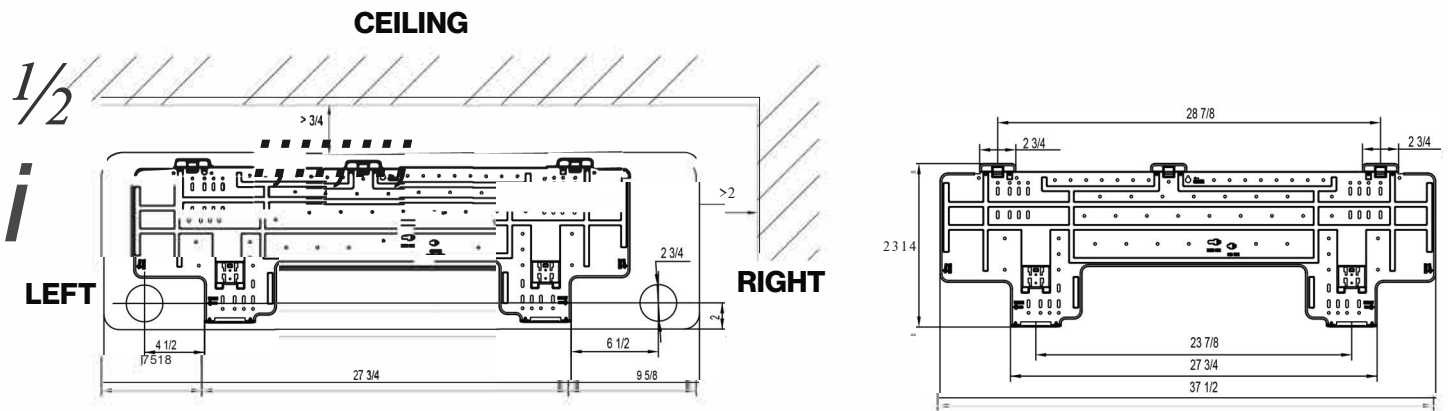
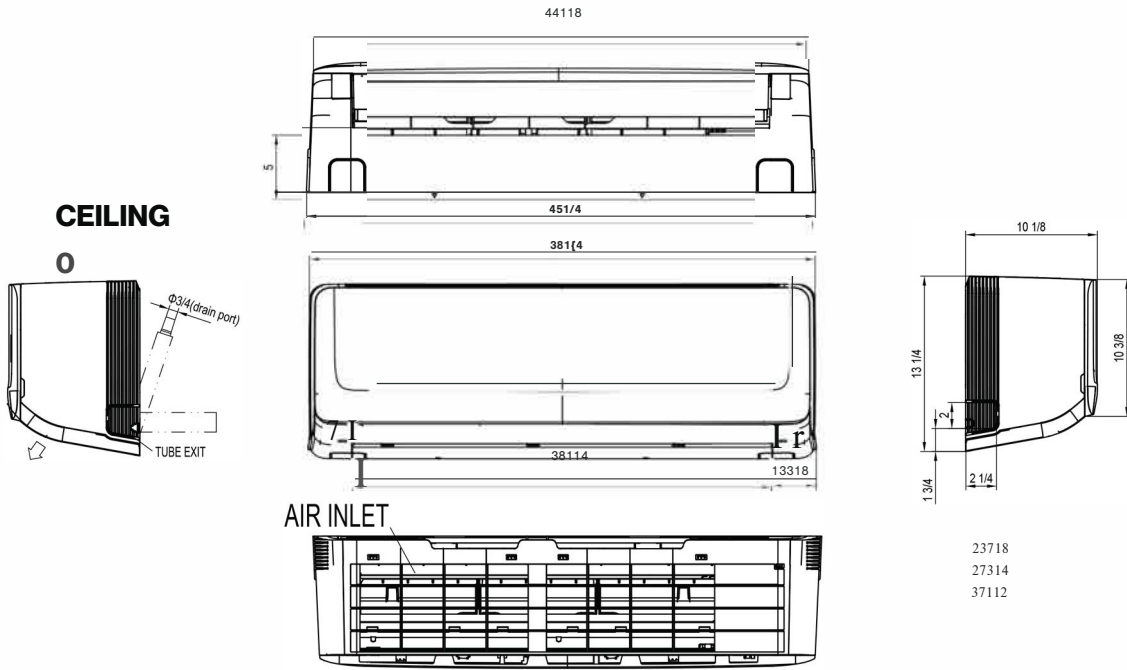

DIMENSIONAL DRAWINGS: CEILING CASSETTE

INDOOR UNIT / FPHFC09A3D,FPHFC12A3D

UNITS: INCHES (MM)

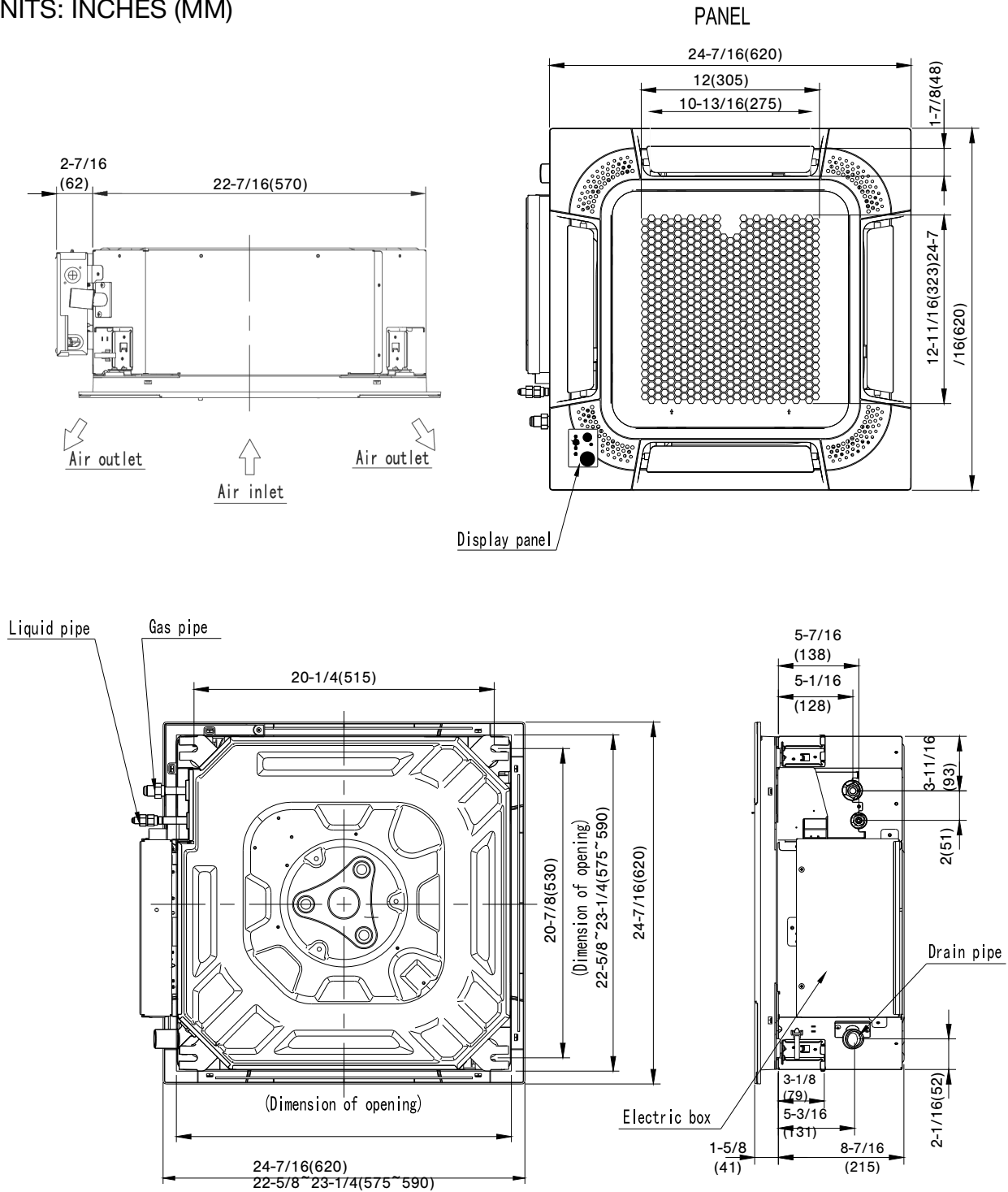

DIMENSIONAL DRAWINGS: CEILING CASSETTE
 INDOOR UNIT / FPHFC18A3D, FPHFC24A3D, FPHSC36A3D

UNITS: INCHES (MM)

18K/24K/36K

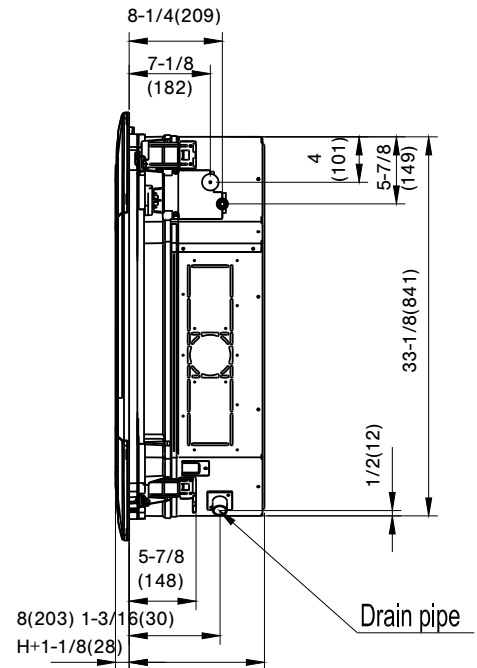
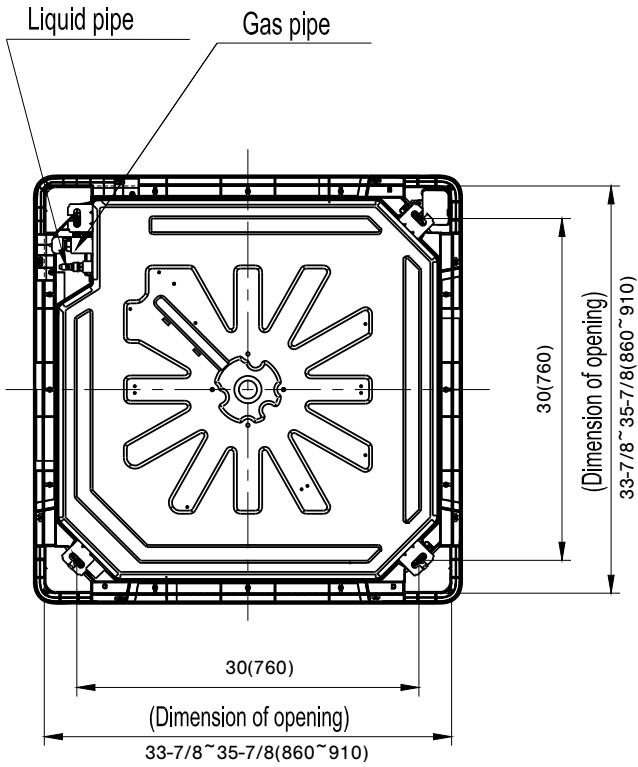
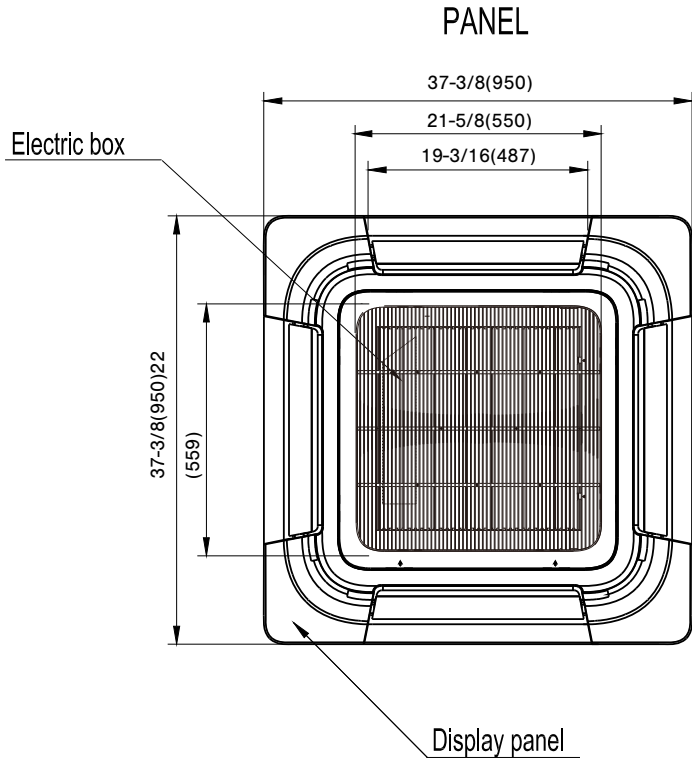
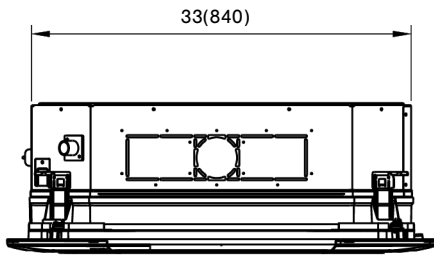

Model	H
18K/24K	236
36K	272

DIMENSIONAL DRAWINGS: CONCEALED DUCTED

INDOOR UNITS / FPHFD09A3D, FPHFD12A3D

UNITS: INCHES (MM)

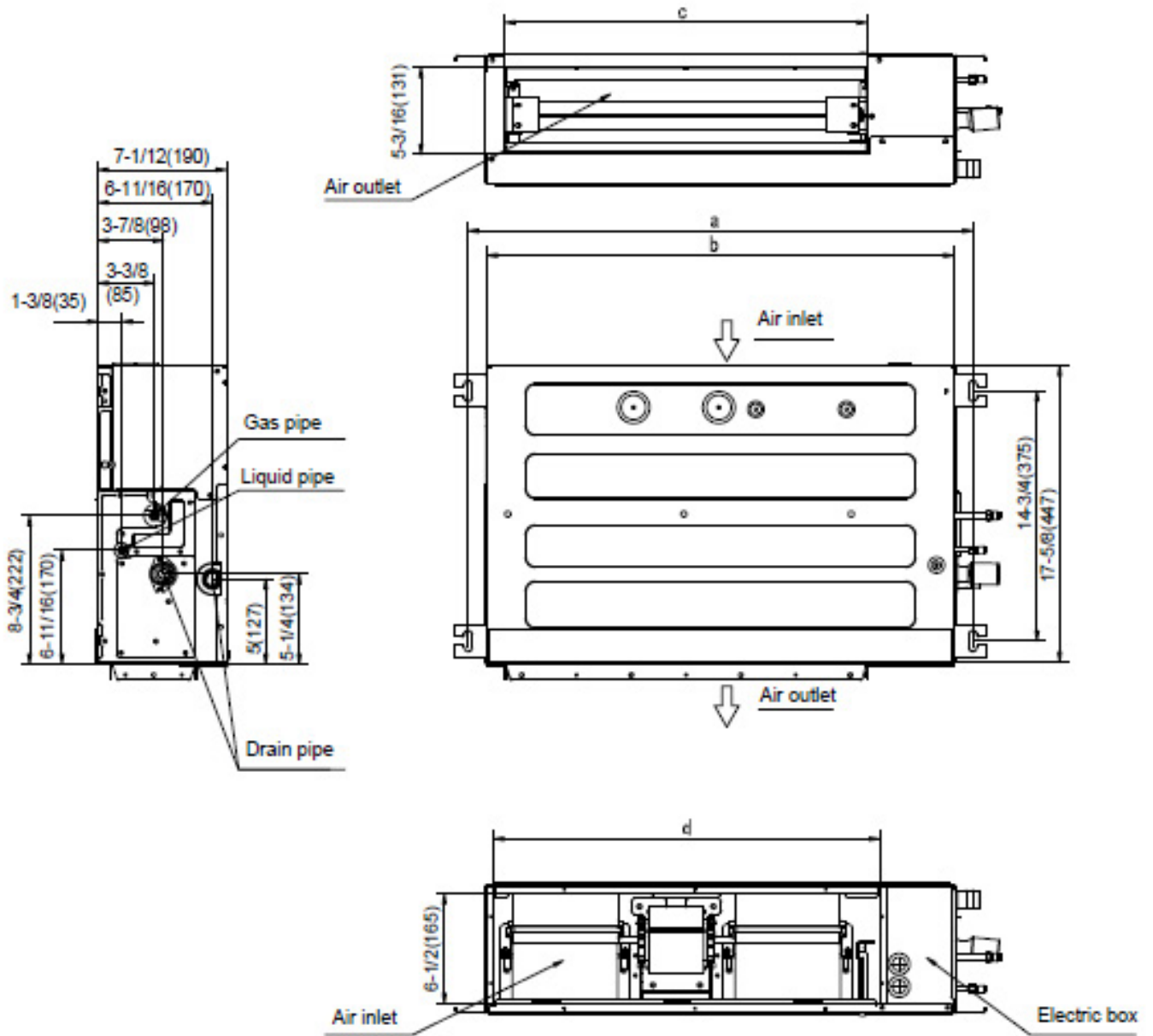

Model (Btu/h)	a	b	c	d
9K/12K	37-13/16 (961)	35-13/16 (910)	29-1/2 (749)	30 (786)

DIMENSIONAL DRAWINGS: CONCEALED DUCTED

INDOOR UNITS / FPHFD18A3D, FPHFD24A3D

UNITS: INCHES (MM)

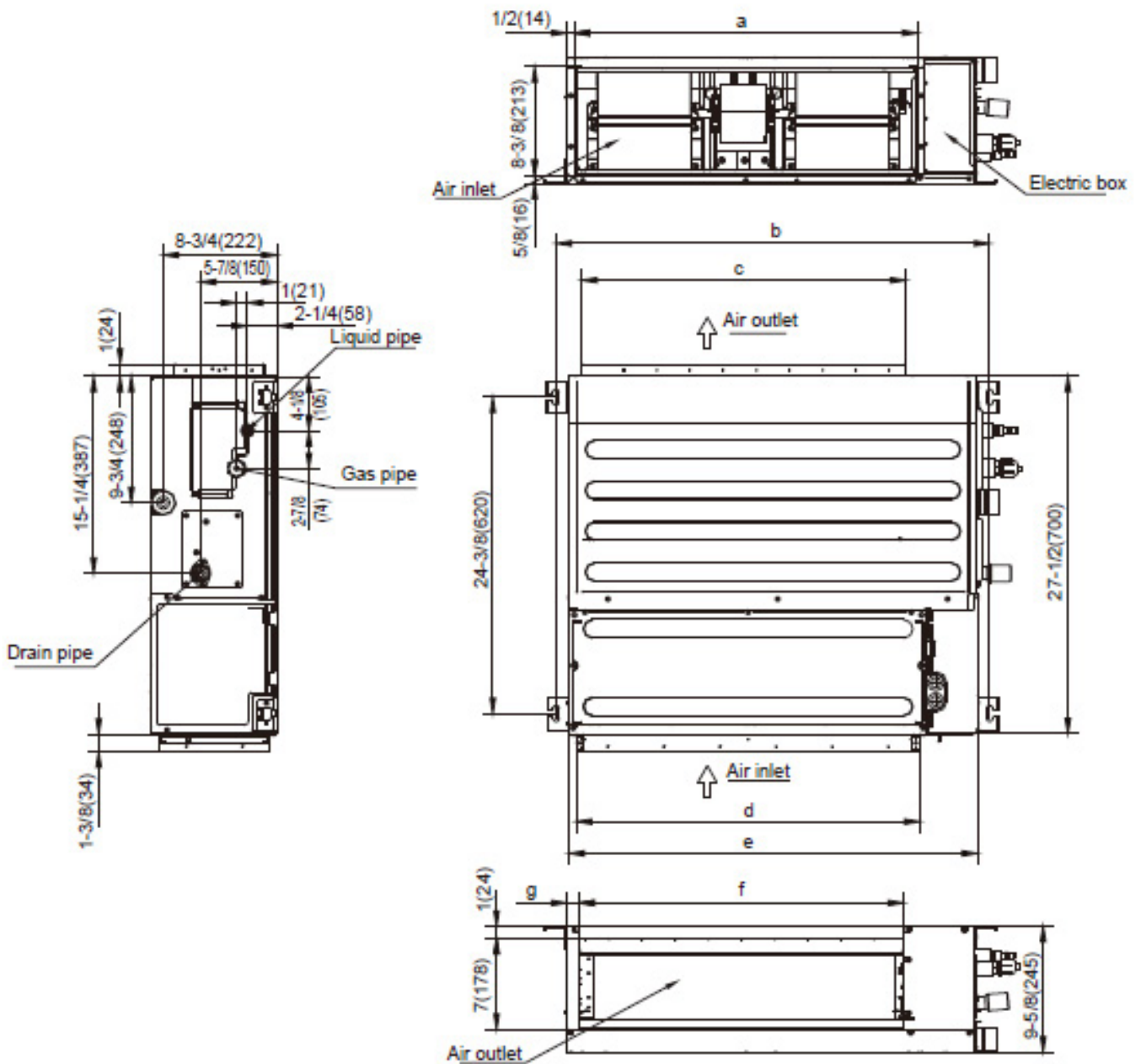

Model (Btu/h)	a	b	c	d	e	f	g
18K	26-1/2 (674)	33-1/2 (850)	25 /636)	26-1/2 (673)	31-1/2 (800)	25 (636)	1 (24)
24K	38-3/8 (974)	45-1/4 (1,150)	35-7/8 /912)	38-1/4 (973)	43-1/4 (1,100)	35-7/8 (912)	1-7/8 (49)

DIMENSIONAL DRAWINGS: CONCEALED DUCTED

INDOOR UNITS / FPHSD36A3D

UNITS: INCHES (MM)

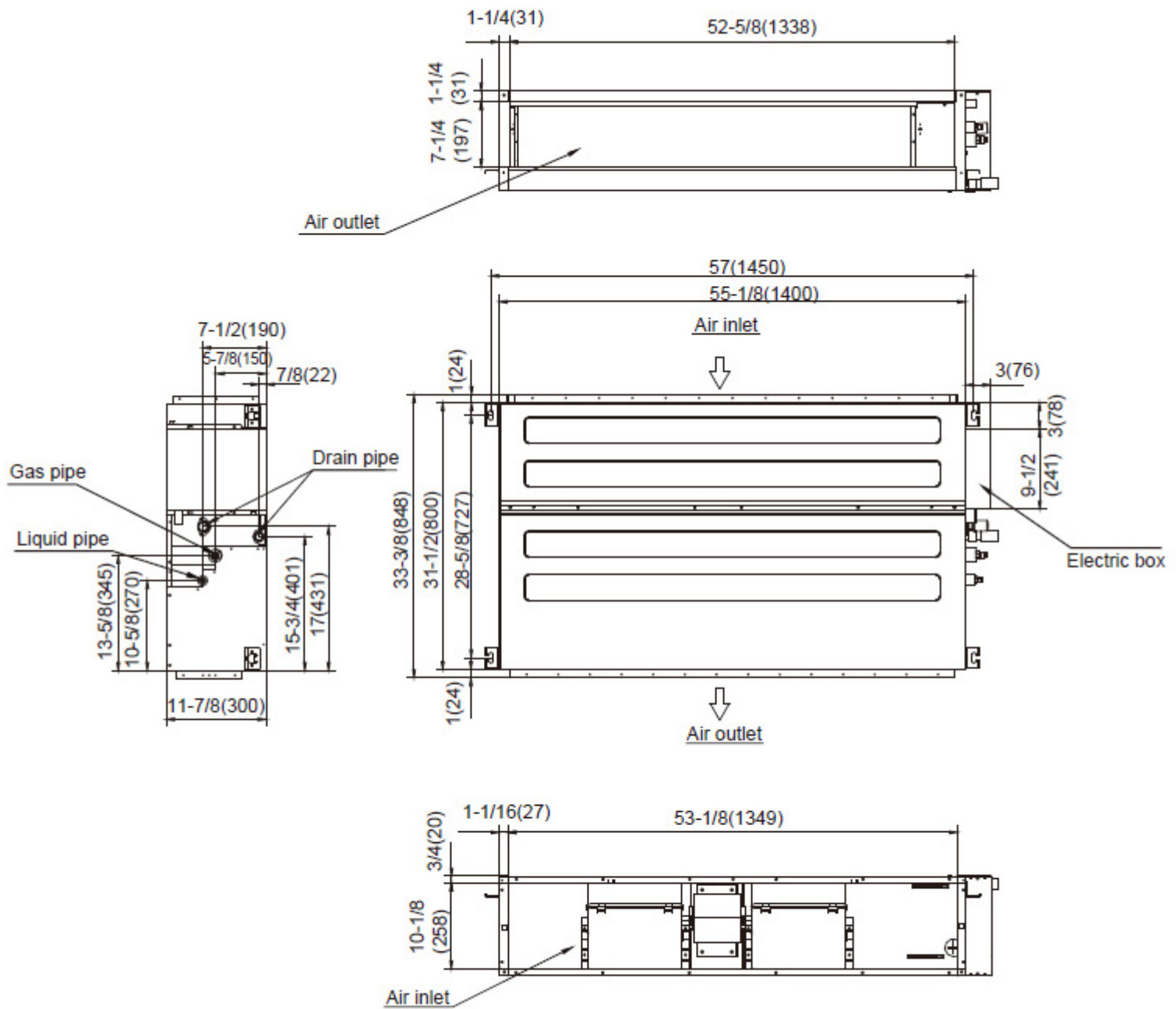

DIMENSIONAL DRAWINGS - AIR HANDLER

INDOOR UNIT / FPHFA18A3D, FPHFA24A3D

UNITS: INCHES (MM)

