

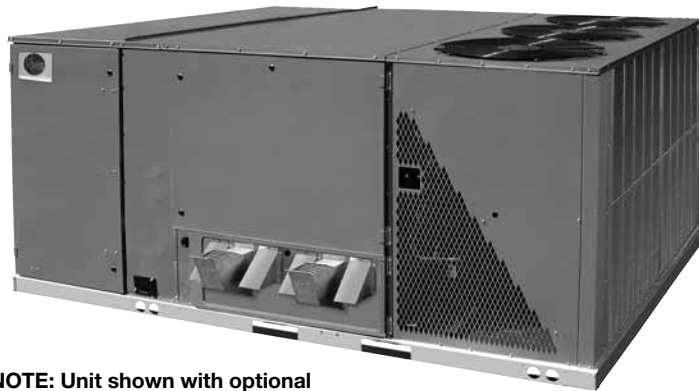

The new degree of comfort.™

H₂AC™ Rooftop Unit featuring eSync™ Integration Technology



NOTE: Unit shown with optional louvered coil protection guard.

RKHL-D Series

- With ClearControl™
- Nominal Size: 15 Ton [52.8 kW]
- ASHRAE 90.1-2010 Compliant Models



RHEEM HIGH EFFICIENCY TANKLESS OR COMMERCIAL TANK RECOMMENDED FOR THE GREATEST ENERGY SAVINGS POTENTIAL.

Rheem Commercial Water Storage Tank:

- 2" fittings
- 80 or 115 Gallon Capacities available



TABLE OF CONTENTS

Unit Features & Benefits	3-9
Model Number Identification	10
Options	11
Selection Procedure	12
<i>eSync Integration Technology</i> [™] Cost Savings Example	13
<i>eSync Integration Technology</i> [™] Typical Piping Example	14
<i>eSync Integration Technology</i> [™] Typical Piping Maximum Length	15
<i>eSync Integration Technology</i> [™] Piping Equivalent Length	16
General Data	
RKHL- Series.....	17-18
General Data Notes.....	19
Gross Systems Performance Data	
RKHL- Series.....	20-21
Airflow Performance	
RKHL- Series	22
Electrical Data	
RKHL- Series	23
Dimensional Data	24-26
Accessories	27-39
Mechanical Specifications	40-46
Wiring Diagrams	47-50
Limited Warranty	51



RKHL-D SERIES STANDARD FEATURES INCLUDE:

- R-410A HFC refrigerant
- Complete factory charged, wired and run tested
- Scroll compressors with internal line break overload and high-pressure protection
- Dual independent compressors for two-stage operation
- Downflow only
- TXV refrigerant metering system
- High Pressure and Low Pressure/Loss of charge protection standard on all models
- Solid Core liquid line filter drier
- Single slab, single pass designed evaporator and condenser coils facilitate easy cleaning for maintained high efficiencies
- Cooling operation up to 125 degree F ambient
- Foil faced insulation encapsulated throughout entire unit minimizes airborne fibers from the air stream
- Hinged major access door with heavy-duty gasketing, 1/4 turn latches and door retainers
- Slide Out Indoor fan assembly for added service convenience
- Powder Paint Finish meets ASTM B117 steel coated on each side for maximum protection G90 galvanized
- One piece base pan with drawn supply and return opening for superior water management
- Forkable base rails for easy handling and lifting
- Single point electrical and gas connections
- Internally sloped slide out condensate pan conforms to ASHRAE 62 standards
- High performance belt drive motor with variable pitch pulleys and quick adjust belt system
- Permanently lubricated evaporator, condenser and gas heat inducer motors
- Condenser motors are internally protected, totally enclosed with shaft down design
- 2 inch filter standard with slide out design
- Two stage gas valve, direct spark ignition, and induced draft for efficiency and reliability
- Tubular heat exchanger
- Solid state furnace control with on board diagnostics
- 24 volt control system with resettable circuit breakers
- Colored and labeled wiring
- Copper tube/Aluminum Fin indoor coils with all aluminum MicroChannel condenser coil
- Factory Installed ClearControl™, a Direct Digital Control (DDC) and sensors which can connect to LonWorks™ or BACnet® BAS systems for remote monitoring and control
- Pressure sensors provide refrigerant pressures, superheat, and subcooling on the ClearControl™ display
- H₂AC Package Unit *featuring eSync Integration Technology* includes water circulation pump, refrigerant-to-water heat exchanger, and *eSync Integration Technology* control board for heat recovery during air conditioning mode to preheat potable water.

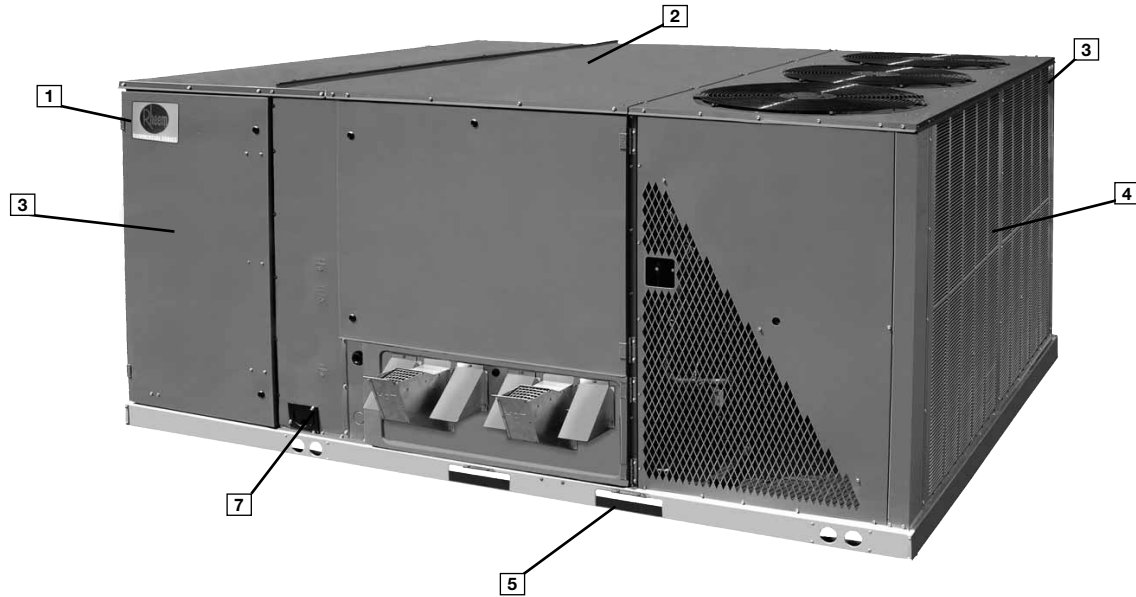

Rheem Package equipment is designed from the ground up with the latest features and benefits required to compete in today's market. The clean design stands alone in the industry and is a testament to the quality, reliability, ease of installation and serviceability that goes into each unit. Outwardly, the large Rheem *Commercial Series*[™] label (1) identifies the brand to the customer.

The sheet-metal cabinet (2) uses nothing less than 18-gauge material for structural components with an underlying coat of G90. To ensure the leak-proof integrity of these units, the design utilizes a top with a 1/8" drip lip (3), gasket-protected panels and screws. The Rheem hail guard (4) (optional) is its trademark, and sets the standard for coil protection in the industry. Every Rheem package unit uses the toughest finish in the industry, using electro deposition baked-on enamel tested to withstand a rigorous 1000-hour salt spray test, per ASTM B117.

Anything built to last must start with the right foundation. In this case, the foundation is 14-gauge, commercial-grade, full-perimeter base rails (5), which integrate fork slots and rigging holes to save set-up time on the job site. The base pan is stamped, which forms a 1-1/8" flange around the supply and return opening and has eliminated the worry of water entering the conditioned space (6). The drainpan (7) is made of material that resists the growth of harmful bacteria and is sloped for the latest IAQ benefits. Furthermore, the drain pan slides out for easy cleaning. The insulation has been placed on the underside of the basepan, removing areas that would allow for potential moisture accumulation, which can facilitate growth of harmful bacteria. All insulation is secured with both adhesive and mechanical fasteners, and all edges are hidden.

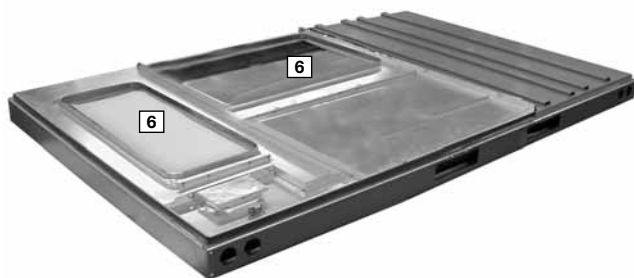

During development, each unit was tested to U.L. 1995, ANSI 21.47, AHRI 340/360 and other Rheem-required reliability tests. Rheem adheres to stringent ISO 9002 quality procedures, and each unit bears the U.L. and AHRI certification labels located on the unit nameplate (8). Contractors can rest assured that when a Rheem package unit arrives at the job, it is ready to go with a factory refrigerant charge and quality checks.

Access is granted with 1/4 turn fasteners and hinged access panels. Access to all major compartments is from the front of the unit, including the filter and electrical compartment, blower compartment, furnace section, and outdoor section. Each panel is permanently embossed with the compartment name (control/filter access, blower access and furnace access).

Electrical and filter compartment access is through a large hinged access panel. The unit charging chart is located on the inside of the electrical and filter compartment door. Electrical wiring diagrams are found on the control box cover, which allows contractors to move them to more readable locations. To the right of the control box the model and serial number can be found. Having this information on the inside will assure model identification for the life of the product. The production line quality test assurance label is also placed in this location (9). The two-inch throwaway filters (10) are on a tracked system for easy removal and replacement.

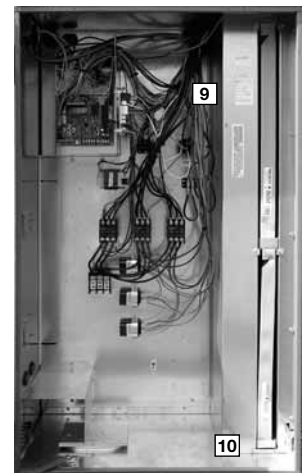

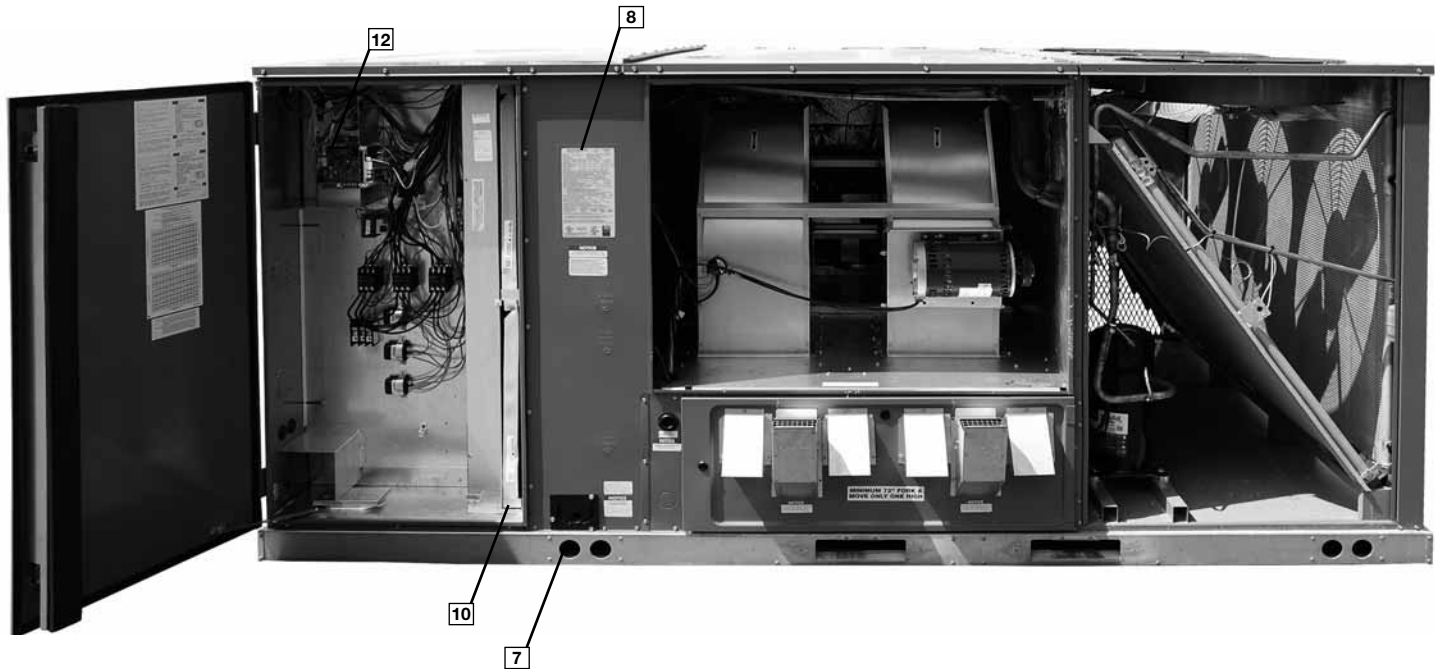

Inside the control box (11), each electrical component is clearly identified with a label that matches the component to the wiring diagram for ease of troubleshooting. All wiring is numbered on each end of the termination and color-coded to match the wiring diagram. The integrated furnace control, used to control furnace operation, incorporates a flashing LED troubleshooting device. Flash codes are clearly outlined on the unit wiring diagram. The control transformer has a low voltage circuit breaker that trips if a low voltage electrical short occurs. There is a blower contactor, and contactor for each compressor.



As part of the ClearControl™ system which allows real time monitoring and communication between rooftop units, the RKHL-D Package Gas/Electric has a Rooftop Unit Controller (RTU-C) factory mounted and wired in the control panel. The RTU-C is a solid-state microprocessor-based control board that provides flexible control and extensive diagnostics for all unit functions. The RTU-C through Proportional/Integral control algorithms perform specific unit functions that govern unit operation in response to: zone conditions, system temperatures, system pressures, ambient conditions and electrical inputs. The RTU-C features a 16 x 2 character LCD display and a five-button keypad for local configuration and direct diagnosis of the system (12). New features include a clogged filter switch (CFS), fan proving switch (FPS), return air temperature sensor (RAT), discharge air temperature sensor (DAT) and outdoor air temperature sensor (OAT). Freeze sensors (FS) are used in place of freezestats to allow measurement of refrigerant suction line

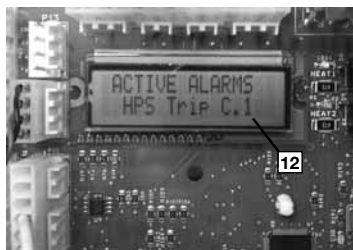

temperatures. The RKHL-D Package Gas/Electric with the RTU-C is specifically designed to be applied in four distinct applications:

The RKHL-D is compatible with a third party building management system that supports the BACnet Application Specific Controller device profile, with the use of a field installed BACnet Communication Module. The BACnet Communication Module plugs onto the unit RTU-C controller and allows communication between the RTU-C and the BACnet MSTP network. A zone sensor, a BACnet network zone sensor, a BACnet thermostat or DDC controller may be used to send the zone temperature or thermostat demands to the RTU-C. The BACnet Communication Module is compatible with MSTP EIA-485 daisy chain networks communicating at 38.4 kbps. It is compatible with twisted pair, shielded cables.

The RKHL-D is compatible with a third party building management system that supports the LonMark Space Comfort Controller (SCC) functional profile or LonMark Discharge Air Controller (DAC) functional profile. This is accomplished with a field installed LonMark communication module. The LonMark Communication Module plugs onto the RTU-C controller and allows communication between the RTU-C and a LonWorks Network. A zone sensor, a LonTalk network zone sensor, or a LonTalk thermostat or DDC controller may be used to send the zone temperature or thermostat demands to the RTU-C. The LonMark Communication Module utilizes an FTT-10A free topology transceiver communicating at 78.8 kbps. It is compatible with Echelon qualified twisted pair cable, Belden 8471 or NEMA Level 4 cables. The Module can communicate up to 1640 ft. with no repeater. The LonWorks limit of 64 nodes per segment applies to this device.

The RKHL-D is compatible with a programmable 24 volt thermostat. Connections are made via conventional thermostat screw terminals. Extensive unit status and diagnostics are displayed on the LCD screen of the RTU-C.

The RKHL-D is compatible with a zone sensor and mechanical or solid state time clock connected to the RTU-C. Extensive unit status and diagnostics are displayed on the LCD screen of the RTU-C.



A factory or field installed Comfort Alert® module is available for power phase-monitoring protection and additional compressor diagnostics. The alarms can be displayed on the RTU-C display, through the (BAS) network, or connected to the “L-Terminal” of a thermostat for notification.

The RKHL-D has a special *eSync Integration Technology* (potable water heating) control board (13) connected to the Rooftop Unit Controller (RTU-C) that allows potable water heat recovery during air conditioning mode. The *eSync Integration Technology* control board adds pressure sensors to provide refrigerant pressures, superheat, and sub-cooling on the RTU-C LCD display.

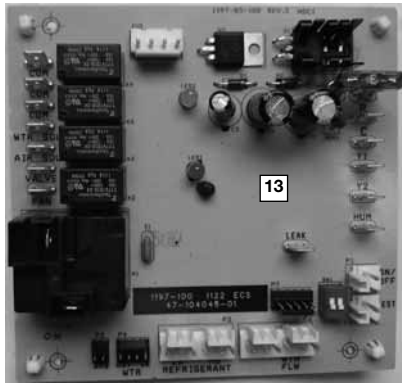

Whenever a call for cooling is present, the Rheem H₂AC Rooftop Unit samples the water storage tank temperature (not included). If the water temperature is below the setpoint, then heat that is normally rejected to the outdoor condenser coil is instead rejected to a heat exchanger in the Rheem H₂AC Rooftop Unit to provide hot water. The setpoint has a default value of 95°F but self-adjusts to jobsite conditions to allow the maximum heat recovery. The preheated water leaving the storage tank for the Rheem H₂AC Rooftop Unit must then be heated to the desired final temperature by a separate tank or tankless water heater.

The RKHL-D includes a water circulation pump (14), a double wall, vented, refrigerant-to-potable water heat exchanger (15), a 3-way refrigerant valve (16) to switch between the outdoor condenser coil and the refrigerant-to-water heat exchanger, idle heat exchanger refrigerant pumpdown solenoid valves (17), and a water pressure switch (18) to prevent operation of the water pump if water is not present. All are controlled by the *eSync Integration Technology* board. The unit also includes an air vent (19) to automatically bleed air from the water lines, and a water leak detector (20) that will shut down water heating operation should a leak be detected and can send an alarm over a BAS network to notify others. In the event of this alarm, an optional field-installed water shut-off valve is available to disconnect the unit from the potable water supply.

The rear of the unit includes potable water line connections to the water storage tank for the Rheem H₂AC Rooftop Unit. For ease of installation, pipe unions (21) are provided to connect to 1-1/2" nominal copper water lines. The lines are provided with plastic covers to keep out contaminants until the system is installed.

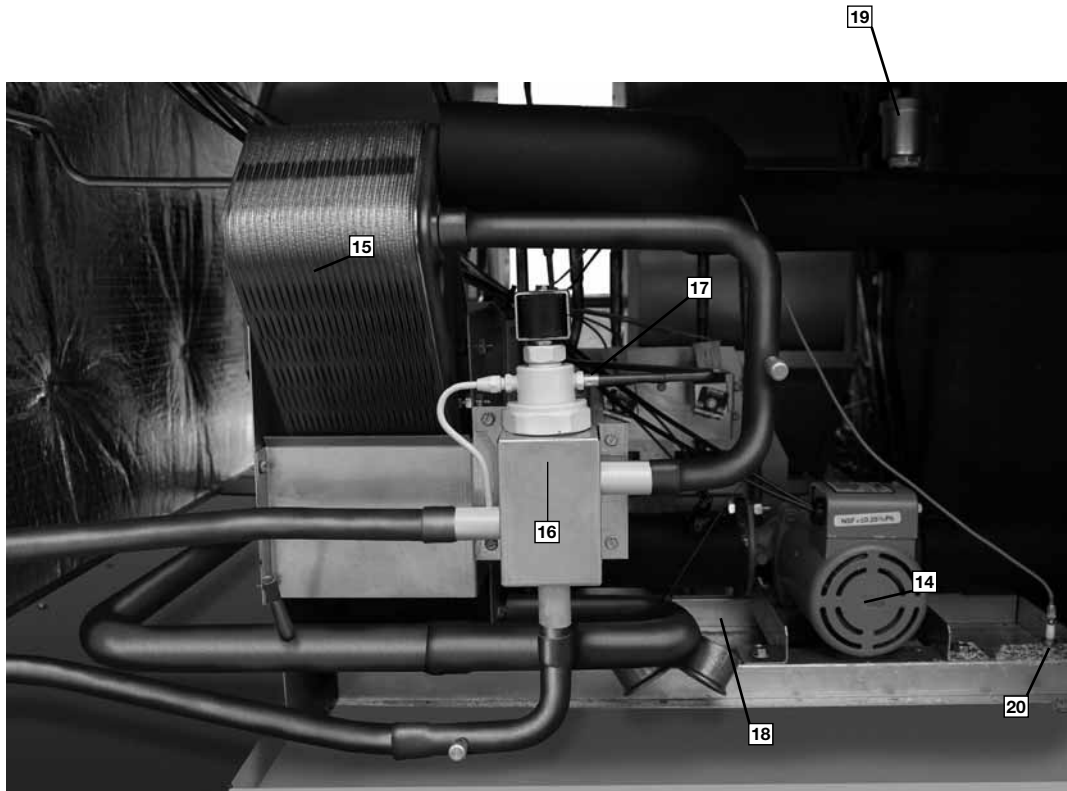
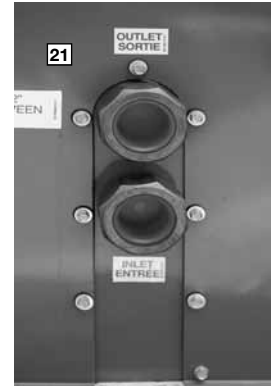

For added convenience in the field, a factory-installed convenience outlet and disconnect (22) are available. Low and High voltage can enter either from the side or through the base. Low-voltage connections are made through the low-voltage terminal strip. For ease of access, the U.L.-required low voltage barrier can be temporarily removed for low-voltage termination and then reinstalled. The high-voltage connection is terminated at the high voltage terminal block. The suggested mounting for the field-installed disconnect is on the exterior side of the electrical control box.



In the outdoor section are the external gauge ports. (23). With gauge ports mounted externally, an accurate diagnostic of system operation can be performed quickly and easily.



The blower compartment is to the right of the control box and can be accessed by 1/4 turn latches. To allow easy maintenance of the blower assembly, the entire assembly easily slides out by removing four #10 screws from the blower assembly. The adjustable motor pulley (24) can easily be adjusted by loosening the bolts on either side of the motor mount. Removing the bolts allows for easy removal of the blower pulley by pushing the blower assembly up to loosen the belt. Once the belt is removed, the motor sheave can be adjusted to the desired number of turns, ranging from 1 to 6 turns open. Where the demands for the job require high static, Rheem has high-static drives available that deliver nominal airflow up to 2" of static. By referring to the airflow performance tables listed in the installation instructions, proper static pressure and CFM requirements can be dialed in. The scroll housing (25) and blower scroll provide quiet and efficient airflow.

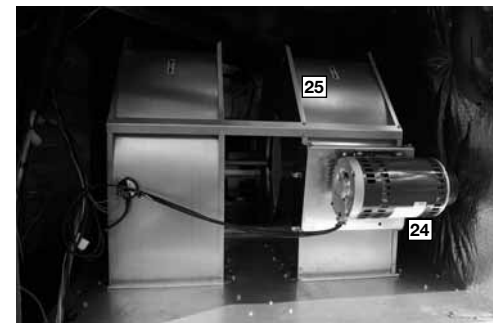

The blower sheave is secured by an "H" bushing which firmly secures the pulley to the blower shaft for years of trouble-free operation. The "H" bushing allows for easy removal of the blower pulley from the shaft, as opposed to the use of a set screw, which can score the shaft, creating burrs that make blower-pulley removal difficult.



Also inside the blower compartment are the optional low-ambient controls (26). The low-ambient controls allow for operation of the compressor down to 0 degrees ambient temperature by cycling the outdoor fans on high pressure. Use of polarized plugs and schrader fittings allow for easy field or factory installation. The freeze sensor clips on the suction line near the evaporator outlet. The freeze sensor protects the compressor if the evaporator coil gets too cold (below freezing) due to low airflow and allows monitoring of the suction line temperature on the controller display.



Inside the blower compartment the interlaced evaporator can also be viewed. The evaporator uses enhanced fin technology for maximum heat transfer. The TXV metering device assures even distribution of refrigerant throughout the evaporator.

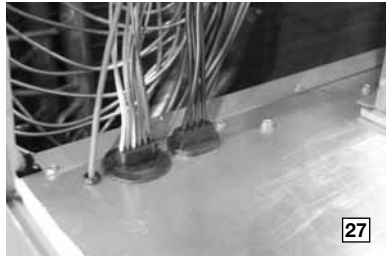

Wiring throughout the unit is neatly bundled and routed. Where wire harnesses go through the condenser bulkhead or blower deck, a molded wire harness assembly (27) provides an air-tight and water-tight seal, and provides strain relief. Care is also taken to tuck raw edges of insulation behind sheet metal to improve indoor air quality.

The furnace compartment contains the latest furnace technology on the market. The draft inducers (28) draw the flame from the Rheem exclusive in-shot burners (29) into the aluminized tubular heat exchanger (30) for clean, efficient gas heat. Stainless steel heat exchangers can be factory installed for those applications that have high fresh-air requirements, or applications in corrosive environments. Each furnace is equipped with a two-stage gas valve (31), which provides two stages of gas heat input. The first stage operates at 50% of the second stage (full fire). 81% steady state efficiency is maintained on both first and second stage by staging the multiple inducers to optimize the combustion airflow and maintain a near stoichiometric burn at each stage.

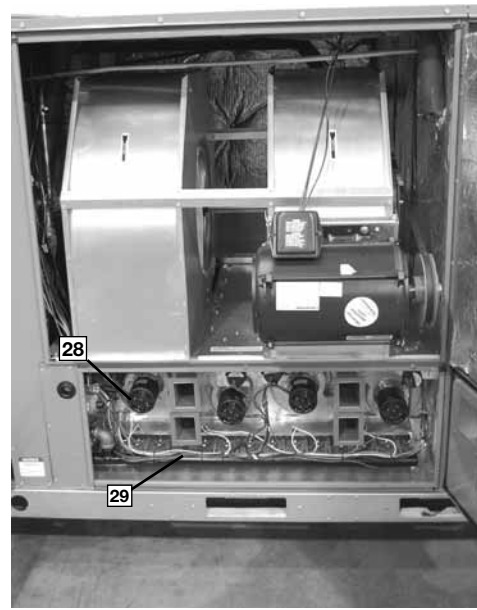

The direct spark igniter (32) assures reliable ignition in the most adverse conditions. This is coupled with remote flame sense (33) to assure that the flame has carried across the entire length of the burner assembly. Gas supply can be routed from the side or up through the base.

Each furnace has the following safety devices to assure consistent and reliable operation after ignition:

- Pressures switches (34) to assure adequate combustion air-flow before ignition.
- Rollout switches (35) to assure no obstruction or cracks in the heat exchanger.
- A limit device that protects the furnace from over-temperature problems.

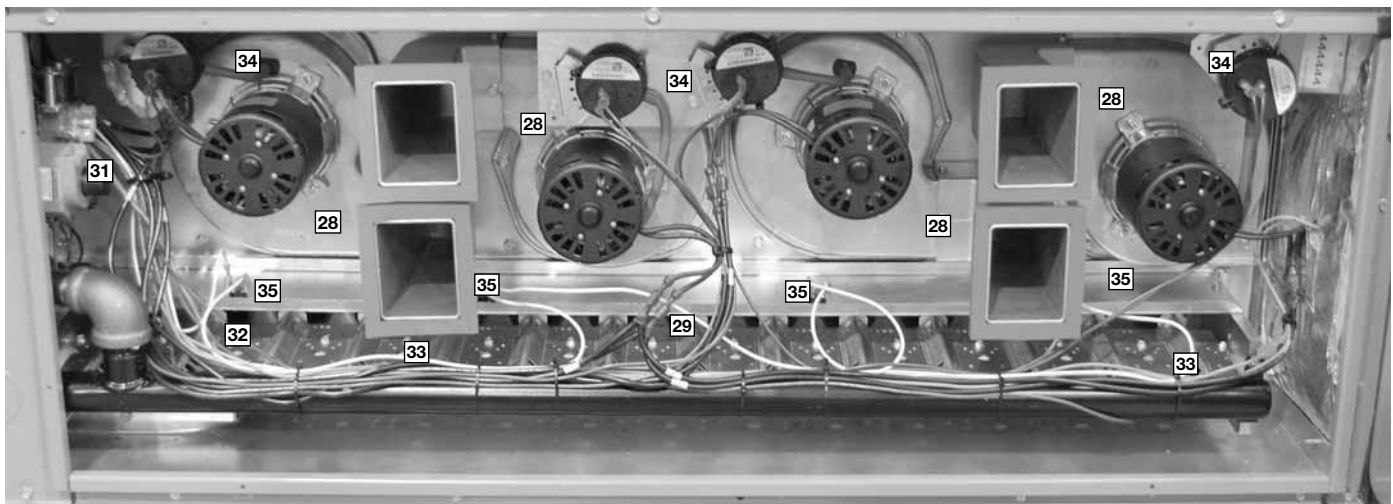

The compressor compartment houses the heartbeat of the unit. The scroll compressor (36) is known for its long life, and for reliable, quiet, and efficient operation. The suction and discharge lines are designed with shock loops (37) to absorb the strain and stress that the starting torque, steady state operation, and shut down cycle impose on the refrigerant tubing. Each compressor and circuit is independent for built-in redundancy, and each circuit is clearly marked throughout the system. Each unit has two stages of efficient cooling operation; first stage is approximately 50% of second stage.

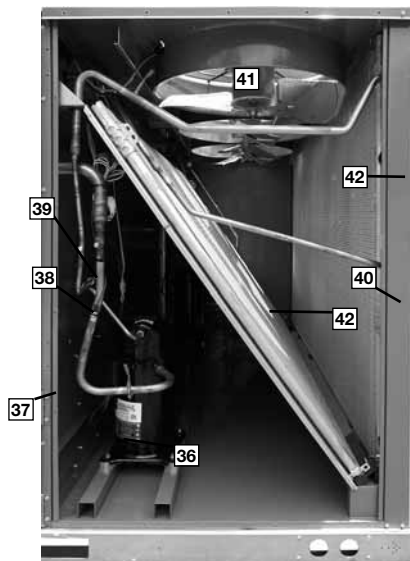

The low-pressure switches (38) and high-pressure switches (39) are mounted on the appropriate refrigerant lines in the condenser section. The high-pressure switch will shut off the compressors if pressures exceeding 610 PSIG are detected as may occur if the outdoor fan motor fails. The low-pressure switches shut off the compressors if low pressure is detected due to loss of refrigerant charge. Each factory-installed option is brazed into the appropriate high or low side and wired appropriately. Use of polarized plugs allow for easy field inspection and repair. Each unit comes standard with filter dryer (40).

The condenser fan motor (41) can easily be accessed and maintained by removing the protective fan grille. The polarized plug connection allows the motor to be changed quickly and eliminates the need to snake wires through the unit.



The outdoor coil uses the latest MicroChannel technology (42) for the most effective method of heat transfer. The outdoor coil is protected by optional louvered panels, which allow unobstructed airflow while protecting the unit from both Mother Nature and vandalism.

These units are designed for downflow applications only (43). The return air compartment (44) can also contain an economizer.

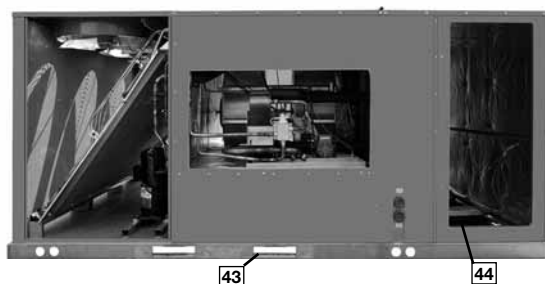

Two economizer models exist for downflow applications (a downflow economizer with factory installed smoke detector in the return section is available. Each unit is prewired for the economizer to allow quick plug-in installation. The economizer is also available as a factory-installed option.

The economizer, which provides free cooling when outdoor conditions are suitable and also provides fresh air to meet local requirements, comes standard with single enthalpy controls. The controls can be upgraded to dual enthalpy easily in the field. The direct drive actuator combined with gear drive dampers has eliminated the need for linkage adjustment in the field. The economizer control has a minimum position setpoint, an outdoor-air enthalpy setpoint, a mixed-air temperature setpoint, and an indoor CO₂ level setpoint.

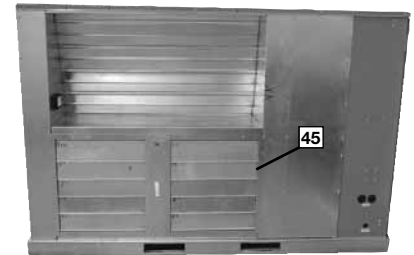

Barometric relief (45) is standard on all economizers. Power Exhaust is easily field installed. The power exhaust is housed in the barometric relief opening and is easily slipped in with a plugin assembly. The wire harness to the economizer also has accommodations for a smoke detector.

The damper minimum position, actual damper position, power exhaust on/off setpoint, mixed air temperature limit setpoint and Demand Controlled Ventilation (DCV) setpoint can be read and adjusted at the unit controller display or remotely through a network connection.

The Space CO₂ level, mixed air temperature, and Economizer Status (Free Cooling Available, Single or Dual Enthalpy) can be read at the unit controller display or remotely through a network connection. Economizer Faults will trigger a network Alarm and can be read at the unit controller display or remotely through a network connection.

The Rheem roofcurb (46) is made for toolless assembly at the jobsite by inserting a pin into a hinge in each corner of the adjacent curb sides (47), which makes the assembly process quick and easy.

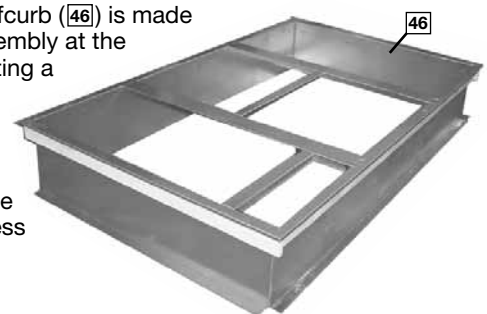

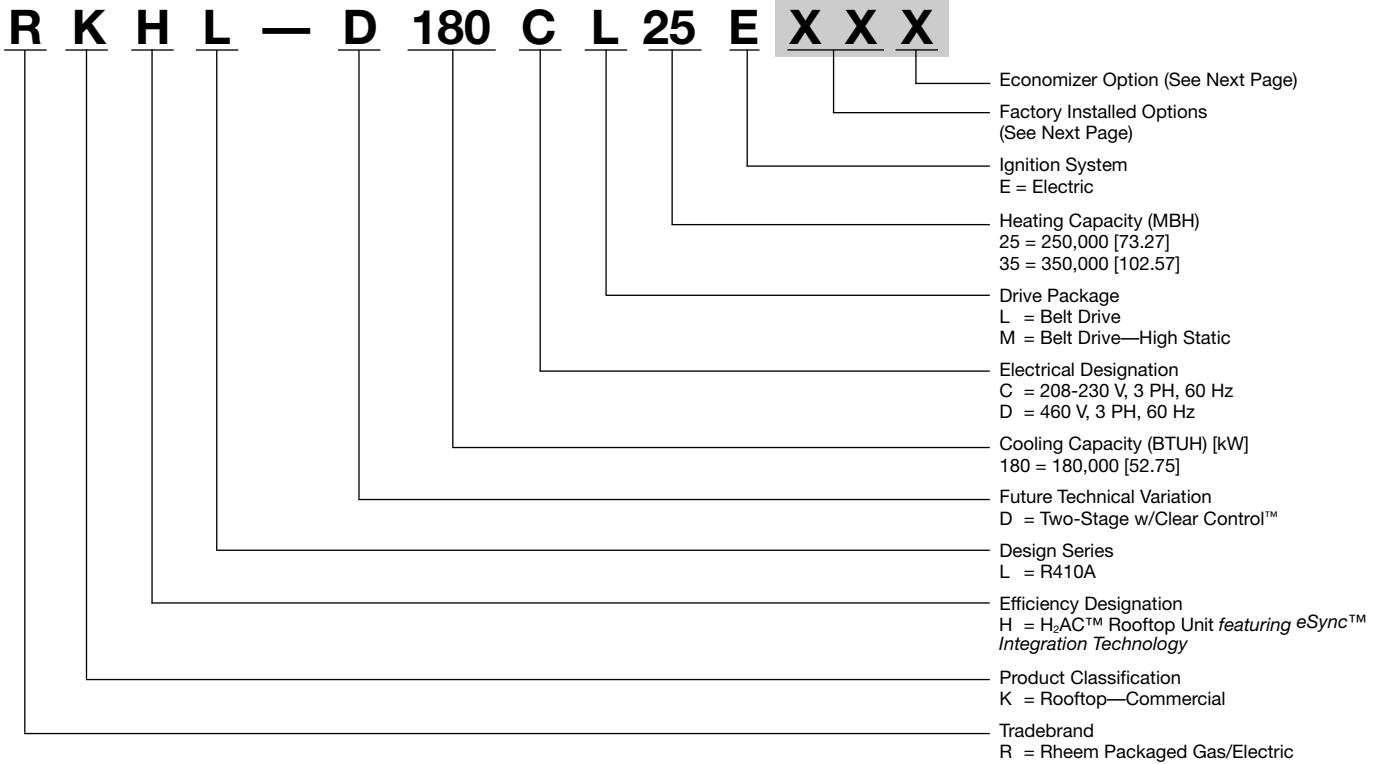

[] Designates Metric Conversions



FACTORY INSTALLED OPTION CODES FOR RKHL-D (15 TON) [52.8 kW]

Option Code	Hail Guard	Stainless Steel Heat Exchanger	Non-Powered Convenience Outlet/Unfused Service Disconnect	Low Ambient/Comfort Alert
AA	No Options			
AD	x			
AJ		x		
AH			x	
AR				x
BF	x			
BG	x	x		
CY		x	x	x
JD	x			x
JB		x	x	
KA	x	x		x
DP	x	x	x	x

NOTES: (1) High and low pressure is standard on all models.
"x" indicates factory installed option.

ECONOMIZER SELECTION FOR RKHL-D (15 TON) [52.8 kW]

Option Code	No Economizer	DDC Single Enthalpy Economizer w/Barometric Relief	DDC Single Enthalpy Economizer w/Barometric Relief and Smoke Detector
A	x		
H		x	
J			x

"x" indicates factory installed option.

Instructions for Factory Installed Option(s) Selection

Note: Three characters following the model number will be utilized to designate a factory-installed option or combination of options. If no factory option(s) is required, nothing follows the model number.

Step 1. After a basic rooftop model is selected, choose a *two-character* option code from the FACTORY INSTALLED OPTION SELECTION TABLE.

Proceed to Step 2.

Step 2. The last option code character is utilized for factory-installed economizers. Choose a character from the FACTORY INSTALLED ECONOMIZER SELECTION TABLE.

Examples:

RKHL-D180CL35Ethis unit has no factory installed options.

RKHL-D180CL35EBGAthis unit is equipped with *hail guard and stainless steel heat exchanger*.

RKHL-D180CL35EAHA.....this unit is equipped with a *non-powered convenience outlet and unfused service disconnect*.

RKHL-D180CL35EAHHthis unit is equipped as above and includes an *Economizer with single enthalpy sensor and with barometric relief*.

RKHL-D180CL35EAAH.....this unit is equipped with an *Economizer with single enthalpy sensor and Barometric Relief*.

[] Designates Metric Conversions



To select an RKHL-D Cooling and Heating unit to meet a job requirement, follow this procedure, with example, using data supplied in this specification sheet.

1. DETERMINE COOLING AND HEATING REQUIREMENTS AND SPECIFIC OPERATING CONDITIONS FROM PLANS AND SPECS.

Example:

Voltage—	208/240V—3 Phase—60 Hz
Total Cooling Capacity—	168,000 BTUH [49.2 kW]
Sensible Cooling Capacity —	120,000 BTUH [35.1 kW]
Heating Capacity —	175,000 BTUH [51.2 kW]
*Condenser Entering Air —	95°F [35.0°C] DB
*Evaporator Mixed Air Entering —	65°F [18.3°C] WB
	78°F [25.6°C] DB
*Indoor Air Flow (vertical) —	6000 CFM [2831 L/s]
*External Static Pressure —	0.40 in. WG [.10 kPa]

2. SELECT UNIT TO MEET COOLING REQUIREMENTS.

Since total cooling is within the range of a nominal 15 ton [52.7 kW] unit, enter cooling performance table at 95°F [35.0 °C] DB condenser inlet air. Interpolate between 63°F [17.2 °C] WB and 67°F [19.4 °C] WB to determine total and sensible capacity and power input for 65°F [18.3 °C] WB evaporator inlet air at 5800 CFM [2737 L/s] indoor air flow (table basis):

Total Cooling Capacity = 178,950 BTUH [52.40 kW]
Sensible Cooling Capacity = 147,400 BTUH [43.16 kW]
Power Input (Compressor and Cond. Fans) = 12,600 watts

Use formula in note (1) to determine sensible capacity at 78°F [25.6 °C] DB evaporator entering air:

$$147,400 + (1.10 \times 6,000 \times (1 - 0.11) \times (78 - 80))$$

$$\text{Sensible Cooling Capacity} = 135,652 \text{ BTUH [39.72 kW]}$$

3. CORRECT CAPACITIES OF STEP 2 FOR ACTUAL AIR FLOW.

Select factors from airflow correction table at 6000 CFM [2831 L/s] and apply to data obtained in step 2 to obtain gross capacity:

Total Capacity = 178,950 x 1.01 = 180,740 BTUH [52.92 kW]
Sensible Capacity = 135,652 x 1.02 = 138,365 BTUH [40.51 kW]
Power Input = 12,600 x 1 = 12,600 Watts

These are Gross Capacities, not corrected for blower motor heat or power.

4. DETERMINE BLOWER SPEED AND WATTS TO MEET SYSTEM DESIGN.

Enter Indoor Blower performance table at 6000 CFM [2831 L/s]. Total ESP (external static pressure) per the spec of 0.40 in. WG [.10 kPa] includes the system duct and grilles. Add from the table 'Component Air Resistance', 0.08 in. WG [.02 kPa] for wet coil, 0 in. WG [.00 kPa] for downflow air flow, for a total selection static pressure of 0.48 (0.5) in. WG [.12 kPa], and determine:

$$\text{RPM} = 631$$

$$\text{WATTS} = 1,824$$

$$\text{DRIVE} = \text{L (standard 3 H.P. motor)}$$

5. CALCULATE INDOOR BLOWER BTUH HEAT EFFECT FROM MOTOR WATTS, STEP 4.

$$1,824 \times 3.412 = 6,223 \text{ BTUH [1.82 kW]}$$

6. CALCULATE NET COOLING CAPACITIES, EQUAL TO GROSS CAPACITY, STEP 3, MINUS INDOOR BLOWER MOTOR HEAT.

$$\text{Net Total Capacity} = 180,740 - 6,223 =$$

$$174,517 \text{ BTUH [51.10 kW]}$$

$$\text{Net Sensible Capacity} = 138,365 - 6,223 =$$

$$132,142 \text{ BTUH [38.69 kW]}$$

7. CALCULATE UNIT INPUT AND JOB EER.

$$\text{Total Power Input} = 12,600 \text{ (step 3)} + 1,824 \text{ (step 4)} = 14,424 \text{ Watts}$$

$$\text{EER} = \frac{\text{Net Total BTUH [kW] (step 6)}}{\text{Power Input, Watts (above)}} = \frac{174,517}{14,424} = 12.1$$

8. SELECT UNIT HEATING CAPACITY.

From Physical Data Table read that gas heating output (input rating x efficiency) is:

$$\text{Heating Capacity} = 203,000 \text{ BTUH [59.4 kW]}$$

9. CHOOSE MODEL RKHL-D180CL25E

*NOTE: These operating conditions are typical of a commercial application in a 95°F/79°F [35°C/26°C] design area with indoor design of 76°F [24°C] DB and 50% RH and 10% ventilation air, with the unit roof mounted and centered on the zone it conditions by ducts.

[] Designates Metric Conversions





Whenever a call for cooling is present, the H₂AC unit samples the temperature of the storage tank for the H₂AC unit. If it is below the setpoint, then heat that is normally rejected to the outdoor condenser coil is instead rejected to a heat exchanger in the H₂AC Unit to provide hot water. The preheated water leaving the storage tank must then be heated to the desired final temperature by a separate tank or tankless heater. The cost savings are provided by the difference between heating water from the ground temperature to the final hot water temperature versus heating water from the storage tank temperature to the final hot water temperature.

1. Calculate daily cost of operation of existing water heating equipment.

Hot Water Consumption (gallons)	Water Specific Weight (lbm/gallon)	Hot Water Temperature (°F)	Ground Water (Cold Water) Temperature (°F)	*Required Water Heating Output (therms)
2100	8.33	185	73.5	19.505

* = 2100 gallons x 8.33 lbm/gallon x (185°F - 73.5 °F) x 1 Btu/(1 lbm x 1 °F) x (1 therm/100,000 Btu)

Water Heater Type	Water Heater Thermal Efficiency	Water Heating Input (therms)	Fuel Cost	Water Heating Cost
Natural Gas Storage Tank	0.80	24.381	\$1.077 per therm (\$/thm)	\$26.26
Propane Gas Storage Tank	0.80	24.381	\$1.210 per gallon of Propane (\$/gal)	\$32.22
Hi-e Natural Gas Storage Tank	0.94	20.750	\$1.077 per therm (\$/thm)	\$22.35
Hi-e Propane Gas Storage Tank	0.94	20.750	\$1.210 per gallon of Propane (\$/gal)	\$27.43
Electric Storage Tank	0.98	19.903	\$0.127 per kiloWatt hour (\$/kWh)	\$74.08
Tankless Natural Gas	0.94	20.750	\$1.077 per therm (\$/thm)	\$22.35
Tankless Propane Gas	0.94	20.750	\$1.210 per gallon of Propane (\$/gal)	\$27.43

(Required Water Heating Output/Thermal Efficiency = Water Heating Input)

2. Calculate daily cost savings from H₂AC operation.

Daily hours when hot water is required without air conditioner operation available 0
 Storage Tank Leaving Water Temperature (°F) - Maximum temperature is 125°F 120
 Required H₂AC Water Heating Output (thm) = 2100 gallons x 8.33 lbm/gallon x (120°F - 73.5 °F) x 1 Btu/(1 lbm x 1 °F) x (1 therm/100,000 Btu) x ((24-0)/24) 8.134

Water Heater Type	Water Heater Thermal Efficiency	Water Heating Input (therms)	Fuel Cost	Water Heating Cost
Natural Gas Storage Tank	0.80	14.213	\$1.077 per therm (\$/thm)	\$15.31
Propane Gas Storage Tank	0.80	14.213	\$1.210 per gallon of Propane (\$/gal)	\$18.79
Hi-e Natural Gas Storage Tank	0.94	12.096	\$1.077 per therm (\$/thm)	\$13.03
Hi-e Propane Gas Storage Tank	0.94	12.096	\$1.210 per gallon of Propane (\$/gal)	\$15.99
Electric Storage Tank	0.98	11.603	\$0.127 per kiloWatt hour (\$/kWh)	\$43.18
Tankless Natural Gas	0.94	12.096	\$1.077 per therm (\$/thm)	\$13.03
Tankless Propane Gas	0.94	12.096	\$1.210 per gallon of Propane (\$/gal)	\$15.99

** (Required Water Heating Output - Required H₂AC Water Heating Output)/Thermal Efficiency

The savings in fuel to provide hot water are offset a bit by higher air conditioning costs in the water heating mode especially during mild weather. The calculations below provide the electrical cost increase for the worst case (mild weather) and for the best case (summer design conditions). The results assume AHRI return air conditions (80°F db/ 67°F wb).

3. Calculate daily increase in electricity cost from H₂AC operation.

Summer Design Outdoor Air Temperature (°F) 95
 Minimum Outdoor Air Temperature, Cooling Mode (°F) 75
 Gross Watts Air Conditioning Mode @ Summer Design Outdoor Air Temperature (kW) from Gross Capacity Tables 12.70
 Gross Watts Air Conditioning Mode @ Minimum Outdoor Air Temperature Cooling Mode (kW) from Gross Capacity Tables 10.50
 Gross Watts Water Heating Mode @ Storage Tank Leaving Water Temperature (kW) from Tables 7.10
 Gross Capacity Water Heating Mode @ Storage Tank Leaving Water Temperature (Btuh) from Tables 119,300
 Gross Watts 2nd Stage Correction (kW) @ Summer Design Outdoor Air Temperature from Tables 6.73
 Gross Watts 2nd Stage Correction (kW) @ Minimum Outdoor Air Temperature from Tables 5.73
 Correction Factor for H₂AC Unit Operation during occupied hours 0.89
 Water Heating Mode Time (hours) = 8.1342 thm x (100,000 Btu/thm) / (0.89 x 119,300 Btu/h) 7.660
 Summer Design Conditions savings decrease = ((24-0) hrs/ 24 hrs) x 7.660 hrs x ((7.1+6.73) - 12.7) kW x 0.127 \$/kWh -\$1.10
 Minimum Outdoor Air Temperature savings decrease = ((24-0) hrs/ 24 hrs) x 7.660 hrs x ((7.1+5.73) - 10.5) kW x 0.127 \$/kWh -\$2.27

4. Subtract the values above from the Water Heating Costs in step 2 to find total daily savings.

For example, replacing a Natural Gas Storage Tank system with an H₂AC unit and a Tankless Natural Gas system will conservatively save \$26.26 - \$13.03 - \$2.27 = \$10.96 per day. The new cost of heating water is only 58% of the original cost. Adding an H₂AC unit to an existing natural gas water heater will conservatively save \$26.26 - \$15.31 - \$2.27 = \$8.68 per day. The new cost of heating water is only 67% of the original cost.



The H₂C system with storage tank can provide any water heating system, tank or tankless, with preheated water.
 The water heating system must be sized properly for each installation.

The tankless system shown below is just one example of a typical installation and may not be suitable for all applications. See the water heater manufacturers recommendation for sizing and product specifications.

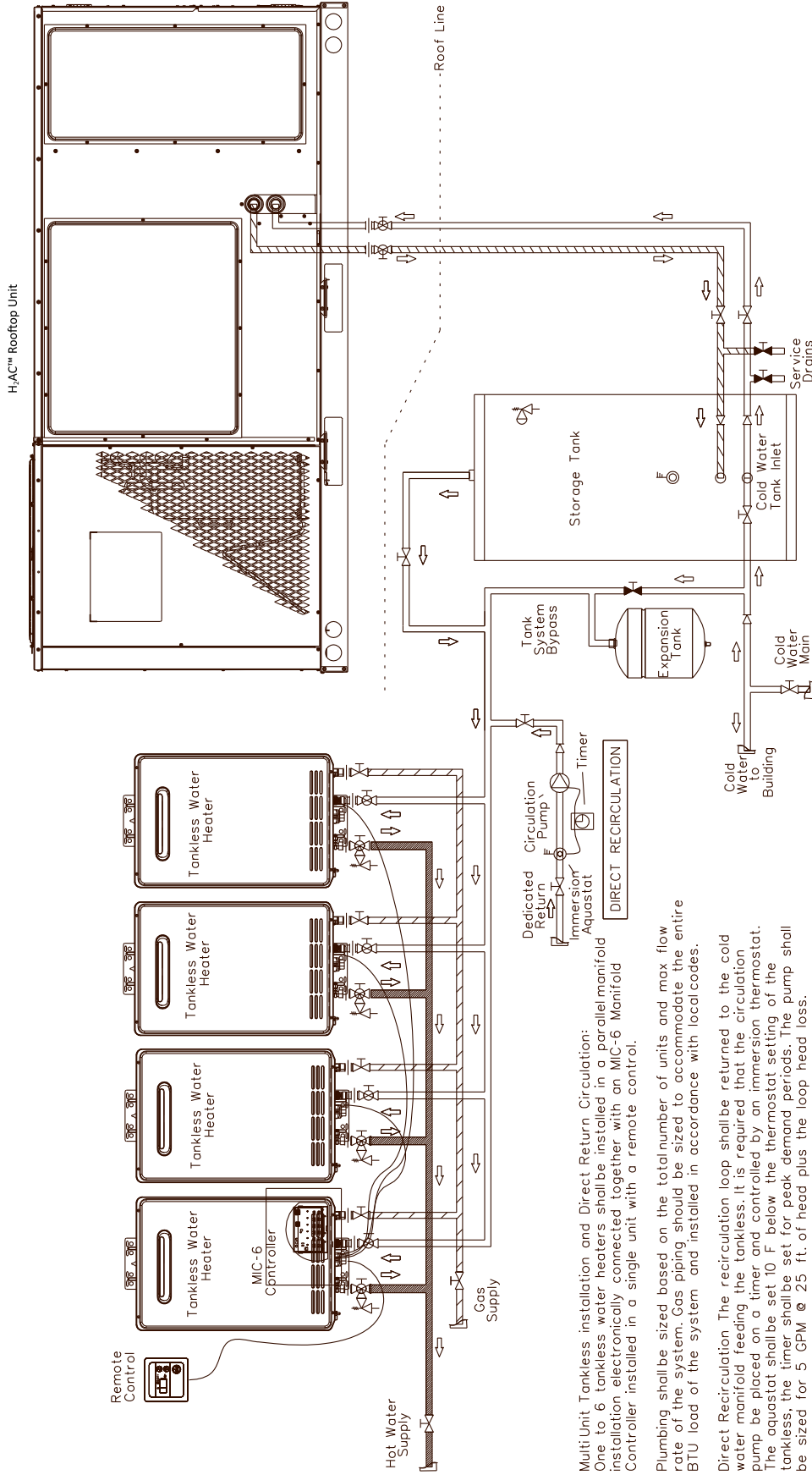

Multi Unit Tankless installation and Direct Return Circulation:
 One to 6 tankless water heaters shall be installed in a parallel manifold installation electronically connected together with an MIC-6 Manifold Controller installed in a single unit with a remote control.

Plumbing shall be sized based on the total number of units and max flow rate of the system. Gas piping should be sized to accommodate the entire BTU load of the system and installed in accordance with local codes.

Direct Recirculation The recirculation loop shall be returned to the cold water manifold feeding the tankless. It is required that the circulation pump be placed on a timer and controlled by an immersion thermostat. The aquastat shall be set 10 F below the thermostat setting of the tankless, the timer shall be set for peak demand periods. The pump shall be sized for 5 GPM @ 25 ft. of head plus the loop head loss.

Legend

- Cold Water Isolator Valve Assembly
- Hot Water Isolator Valve Assembly
- Circulation Pump
- Pressure Relief Valve
- Normally Open Shut-off Valve
- Normally Closed Shut-off Valve
- Check Valve
- Union
- Gas Pipe
- Cold Water Pipe
- Hot Water Pipe
- Return Circulation Line

This drawing is intended as a guide only. It is not to be used as an alternative to a professionally engineered project drawing. This drawing does not imply compliance with local building codes. Installation may vary, depending on installation location, and must be done in accordance with all local building codes. Consult with local building officials prior to installation.



Chart below shows the H₂AC Rooftop Unit Water Flow Rate versus the Available Pressure Water Pressure drop. When selecting the location of the H₂AC Rooftop Unit, do not exceed the maximum Equivalent Feet of tubing between the H₂AC Rooftop Unit and the storage tank to ensure proper performance at available voltage. Higher GPM will provide a higher storage tank temperature.

Water Flow Rate (GPM) (15 GPM minimum)		15	20	25	30
Water Velocity (fps)		2.71	3.61	4.51	5.41
Available Pressure Head at Unit @ 230/460 Volts	(Head ft.)	30.3	23.8	16.3	7.7
	(psig)	13.1	10.3	7.1	3.3
Maximum Equivalent Feet of 1-1/2" Nom. Type L Copper Tubing (ft.)		1504	695	314	106
Available Pressure Head at Unit @ 208 Volts	(Head ft.)	26.8	19.5	11.3	2.2
	(psig)	11.6	8.4	4.9	0.9
Maximum Equivalent Feet of 1-1/2" Nom. Type L Copper Tubing (ft.)		1332	569	218	30

In a closed system application the static (elevation) head is ignored. Only the pipe friction is used to calculate pressure drop.

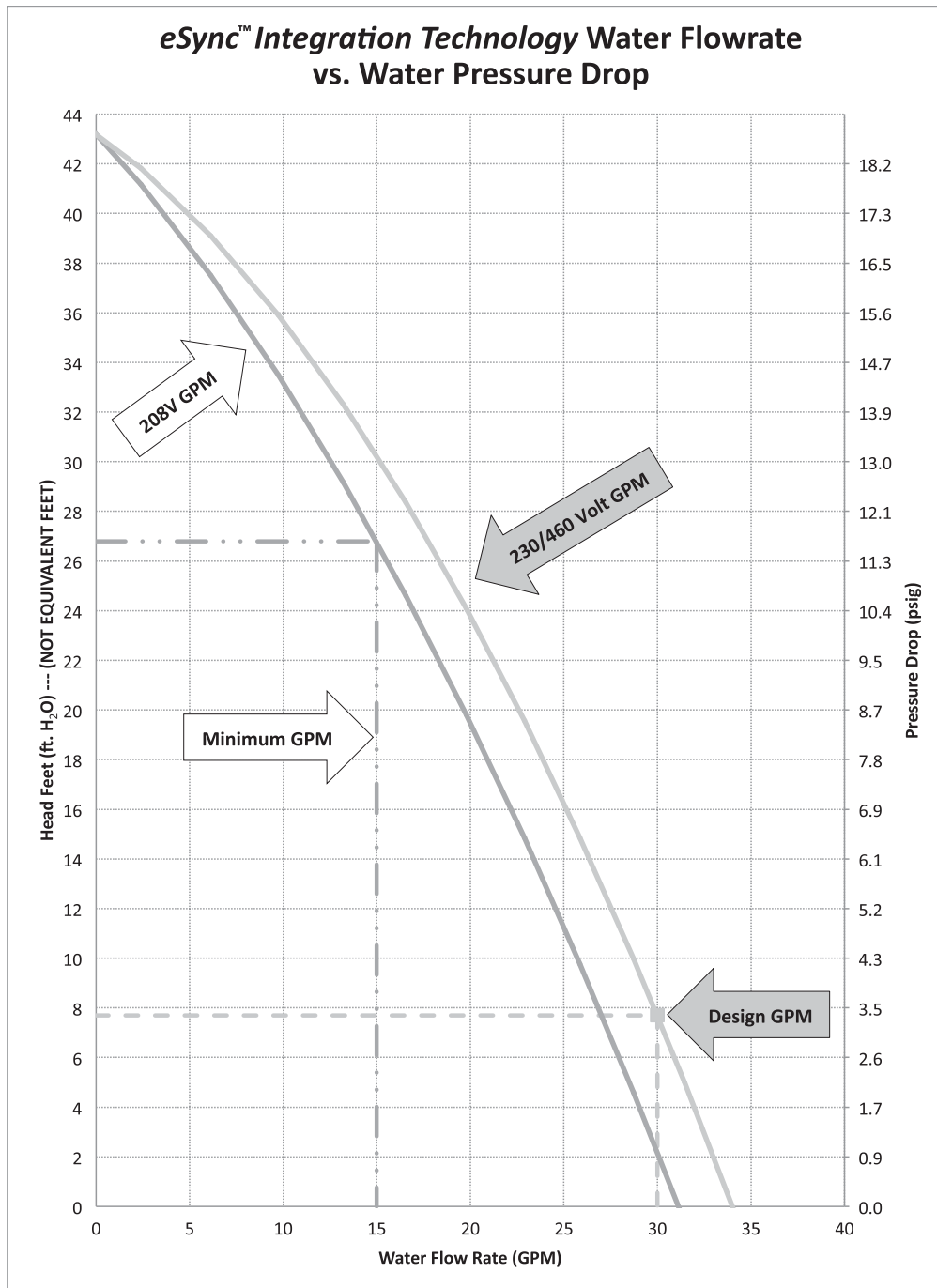

PROCEDURE FOR CALCULATING THE TOTAL EQUIVALENT LENGTH OF TUBING

List all piping components from the Storage Tank to the H₂AC Rooftop Unit, and H₂AC Rooftop Unit back to the Storage Tank. The equivalent length of straight tubing is the same as the actual length. The equivalent length of fittings are obtained from the table below. To find the Total Equivalent Length of fittings, sum all of the individual component lengths.

PRESSURE LOSS IN FITTINGS AND VALVES EXPRESSED AS EQUIVALENT LENGTH OF TUBE (FT.)

Tube Nominal or Standard Size (inches)		1-1/2"	2"
Fittings	Standard 90° Elbow	4	5.5
	Standard 45° Elbow	1.5	2
	90° Tee - Side Branch	7	9
	90° Tee - Straight Run	0.5	0.5
	Coupling	0.5	0.5
Valves	Ball	0.5	0.5
	Gate	—	0.5
	Btfly	—	0.5
	Check	6.5	9

Data condensed from Table 7 "Pressure Loss in Fittings & Valves Expressed as Equivalent Length of Tube" of the Copper Development Association. Allowances are for streamlined soldered fittings and recessed threaded fittings. The equivalent lengths presented above are based upon a C factor of 150 in the Hazen-Williams friction loss formula. The lengths shown are rounded to the nearest half foot.

TOTAL EQUIVALENT LENGTH OF FITTINGS

No.	Inlet	EQUIVALENT Length (ft.)	No.	Outlet	EQUIVALENT Length (ft.)
1	side branch Tee	7	18	straight tubing	1
2	straight tubing	1	19	90° elbow	4
3	Check valve	6.5	20	straight tubing	0.5
4	straight tubing	0.5	21	1-1/2" MPT adapter ①	1
5	straight run Tee	0.5	22	Ball Isolation valve	0.5
6	straight tubing	1.5	23	1-1/2" MPT adapter ①	1
7	Ball valve	0.5	24	straight tubing	20
8	straight tubing	5	25	coupling	0.5
9	90° elbow	4	26	straight tubing	19.6
10	straight tubing	20	27	90° elbow	4
11	coupling	0.5	28	straight tubing	4
12	straight tubing	20	29	Ball valve	0.5
13	1-1/2" MPT adapter ①	1	30	straight tubing	1.5
14	Ball Isolation valve	0.5	31	straight run Tee	0.5
15	1-1/2" MPT adapter ①	1	32	straight tubing	0.5
16	straight tubing	0.5	33	Check valve	6.5
17	90° elbow - fitting	4	34	straight tubing	1
			35	90° elbow	4
Total Equivalent Length					144.6 (ft.)

*NOTES: ① For threaded fittings, double the allowances shown in the table.

PIPE FITTINGS BY NUMBER

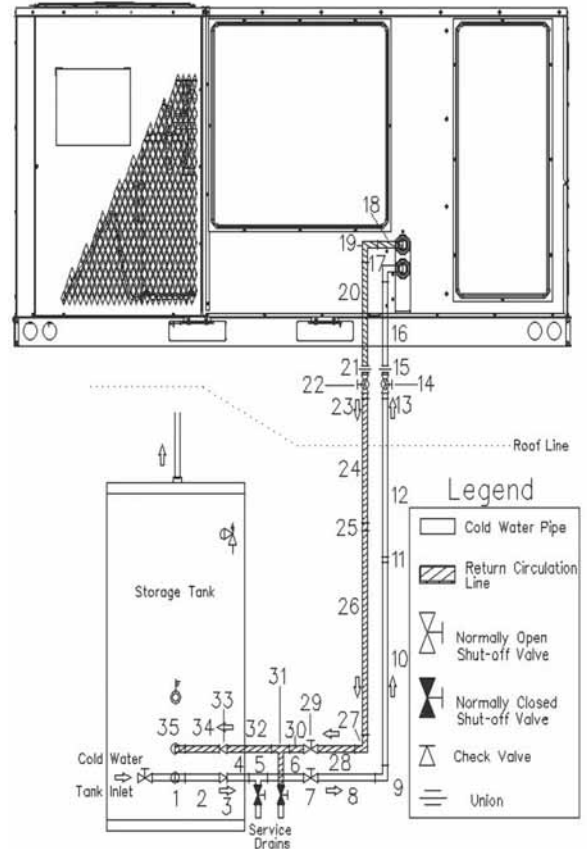

NOM. SIZES 15 TON [52.8 kW] ASHRAE 90.1-2007 COMPLIANT MODELS

Model RKHL- Series	D180CL25E	D180CL35E	D180CM25E	D180CM35E
Cooling Performance¹				CONTINUED →
Gross Cooling Capacity Btu [kW]	182,000 [53.33]	182,000 [53.33]	182,000 [53.33]	182,000 [53.33]
EER/SEER ²	12.4/NA	12.4/NA	12.4/NA	12.4/NA
Nominal CFM/AHRI Rated CFM [L/s]	6000/5800 [2831/2737]	6000/5800 [2831/2737]	6000/5800 [2831/2737]	6000/5800 [2831/2737]
AHRI Net Cooling Capacity Btu [kW]	176,000 [51.57]	176,000 [51.57]	176,000 [51.57]	176,000 [51.57]
Net Sensible Capacity Btu [kW]	130,400 [38.21]	130,400 [38.21]	130,400 [38.21]	130,400 [38.21]
Net Latent Capacity Btu [kW]	45,600 [13.36]	45,600 [13.36]	45,600 [13.36]	45,600 [13.36]
IEER ³	13	13	13	13
Net System Power kW	14.23	14.23	14.23	14.23
Heating Performance (Gas)⁴				
Heating Input Btu [kW] (1st Stage / 2nd Stage)	125,000/250,000 [36.62/73.25]	175,000/350,000 [51.27/102.55]	125,000/250,000 [36.62/73.25]	175,000/350,000 [51.27/102.55]
Heating Output Btu [kW] (1st Stage / 2nd Stage)	101,500/203,000 [29.74/59.48]	142,000/284,000 [41.61/83.21]	101,500/203,000 [29.74/59.48]	142,000/284,000 [41.61/83.21]
Temperature Rise Range °F [°C] (1st / 2nd Stage)	15-45 [8.3-25] / 15-45 [8.3-25]	30-60 [16.7-33.3] / 30-60 [16.7-33.3]	15-45 [8.3-25] / 15-45 [8.3-25]	30-60 [16.7-33.3] / 30-60 [16.7-33.3]
Steady State Efficiency (%)	81	81	81	81
No. Burners	10	14	10	14
No. Stages	2	2	2	2
Gas Connection Pipe Size in. [mm]	0.75 [19]	0.75 [19]	0.75 [19]	0.75 [19]
Compressor				
No./Type	2/Scroll	2/Scroll	2/Scroll	2/Scroll
Outdoor Sound Rating (dB)⁵	91	91	91	91
Outdoor Coil—Fin Type	Louvered	Louvered	Louvered	Louvered
Tube Type	MicroChannel	MicroChannel	MicroChannel	MicroChannel
MicroChannel Depth in. [mm]	1 [25.4]	1 [25.4]	1 [25.4]	1 [25.4]
Face Area sq. ft. [sq. m]	50.8 [4.72]	50.8 [4.72]	50.8 [4.72]	50.8 [4.72]
Rows / FPI [FPcm]	1 / 23 [9]	1 / 23 [9]	1 / 23 [9]	1 / 23 [9]
Indoor Coil—Fin Type	Louvered	Louvered	Louvered	Louvered
Tube Type	Rifled	Rifled	Rifled	Rifled
Tube Size in. [mm]	0.375 [9.5]	0.375 [9.5]	0.375 [9.5]	0.375 [9.5]
Face Area sq. ft. [sq. m]	26.67 [2.48]	26.67 [2.48]	26.67 [2.48]	26.67 [2.48]
Rows / FPI [FPcm]	2 / 18 [7]	2 / 18 [7]	2 / 18 [7]	2 / 18 [7]
Refrigerant Control	TX Valves	TX Valves	TX Valves	TX Valves
Drain Connection No./Size in. [mm]	1/1 [25.4]	1/1 [25.4]	1/1 [25.4]	1/1 [25.4]
Outdoor Fan—Type	Propeller	Propeller	Propeller	Propeller
No. Used/Diameter in. [mm]	3/24 [609.6]	3/24 [609.6]	3/24 [609.6]	3/24 [609.6]
Drive Type/No. Speeds	Direct/1	Direct/1	Direct/1	Direct/1
CFM [L/s]	10000 [4719]	10000 [4719]	10000 [4719]	10000 [4719]
No. Motors/HP	3 at 1/3 HP	3 at 1/3 HP	3 at 1/3 HP	3 at 1/3 HP
Motor RPM	1075	1075	1075	1075
Indoor Fan—Type	FC Centrifugal	FC Centrifugal	FC Centrifugal	FC Centrifugal
No. Used/Diameter in. [mm]	2/18x9 [457x229]	2/18x9 [457x229]	2/18x9 [457x229]	2/18x9 [457x229]
Drive Type	Belt (Adjustable)	Belt (Adjustable)	Belt (Adjustable)	Belt (Adjustable)
No. Speeds	Single	Single	Single	Single
No. Motors	1	1	1	1
Motor HP	3	3	5	5
Motor RPM	1725	1725	1725	1725
Motor Frame Size	56	56	184	184
Portable Water Heat Recovery				
Heat Exchanger Type	Vented Double-Wall Flat Plate	Vented Double-Wall Flat Plate	Vented Double-Wall Flat Plate	Vented Double-Wall Flat Plate
Material	Cu Brazed Stainless Steel	Cu Brazed Stainless Steel	Cu Brazed Stainless Steel	Cu Brazed Stainless Steel
No. Flat Plates	50	50	50	50
Unit Water Connections No./Size in. [mm]	2/1.625 [41.3]	2/1.625 [41.3]	2/1.625 [41.3]	2/1.625 [41.3]
Water Pump - Type	Centrifugal	Centrifugal	Centrifugal	Centrifugal
Drive Type/No. Speeds	Direct/1	Direct/1	Direct/1	Direct/1
Housing Material	Stainless Steel	Stainless Steel	Stainless Steel	Stainless Steel
GPM [L/s]	30 [1.89]	30 [1.89]	30 [1.89]	30 [1.89]
Head Pressure ft. H2O [kPa]	25 [74.7]	25 [74.7]	25 [74.7]	25 [74.7]
Motor HP	1/3	1/3	1/3	1/3
Motor RPM	3450	3450	3450	3450
Filter - Type	Disposable	Disposable	Disposable	Disposable
Furnished	Yes	Yes	Yes	Yes
(NO.) Size Recommended in. [mm x mm x mm]	(8)2x25x20 [51x635x508]	(8)2x25x20 [51x635x508]	(8)2x25x20 [51x635x508]	(8)2x25x20 [51x635x508]
Refrigerant Charge Oz. [g]	171/201 [4848/5698]	171/201 [4848/5698]	171/201 [4848/5698]	171/201 [4848/5698]
Weights				
Net Weight lbs. [kg]	2027 [919]	2040 [925]	2056 [933]	2069 [938]
Ship Weight lbs. [kg]	2154 [977]	2167 [983]	2183 [990]	2196 [996]

See Page 19 for Notes.

[] Designates Metric Conversions



NOM. SIZES 15 TON [52.8 kW] ASHRAE 90.1-2007 COMPLIANT MODELS

Model RKHL- Series	D180DL25E	D180DL35E	D180DM25E	D180DM35E
Cooling Performance¹				
Gross Cooling Capacity Btu [kW]	182,000 [53.33]	182,000 [53.33]	182,000 [53.33]	182,000 [53.33]
EER/SEER ²	12.4/NA	12.4/NA	12.4/NA	12.4/NA
Nominal CFM/AHRI Rated CFM [L/s]	6000/5800 [2831/2737]	6000/5800 [2831/2737]	6000/5800 [2831/2737]	6000/5800 [2831/2737]
AHRI Net Cooling Capacity Btu [kW]	176,000 [51.57]	176,000 [51.57]	176,000 [51.57]	176,000 [51.57]
Net Sensible Capacity Btu [kW]	130,400 [38.21]	130,400 [38.21]	130,400 [38.21]	130,400 [38.21]
Net Latent Capacity Btu [kW]	45,600 [13.36]	45,600 [13.36]	45,600 [13.36]	45,600 [13.36]
IEER ³	13	13	13	13
Net System Power kW	14.23	14.23	14.23	14.23
Heating Performance (Gas)⁴				
Heating Input Btu [kW] (1st Stage / 2nd Stage)	125,000/250,000 [36.62/73.25]	175,000/350,000 [51.27/102.55]	125,000/250,000 [36.62/73.25]	175,000/350,000 [51.27/102.55]
Heating Output Btu [kW] (1st Stage / 2nd Stage)	101,500/203,000 [29.74/59.48]	142,000/284,000 [41.61/83.21]	101,500/203,000 [29.74/59.48]	142,000/284,000 [41.61/83.21]
Temperature Rise Range °F [°C] (1st / 2nd Stage)	15-45 [8.3-25] /	30-60 [16.7-33.3] /	15-45 [8.3-25] /	30-60 [16.7-33.3] /
Steady State Efficiency (%)	81	81	81	81
No. Burners	10	14	10	14
No. Stages	2	2	2	2
Gas Connection Pipe Size in. [mm]	0.75 [19]	0.75 [19]	0.75 [19]	0.75 [19]
Compressor				
No./Type	2/Scroll	2/Scroll	2/Scroll	2/Scroll
Outdoor Sound Rating (dB)⁵				
	91	91	91	91
Outdoor Coil—Fin Type				
Tube Type	Louvered	Louvered	Louvered	Louvered
MicroChannel Depth in. [mm]	MicroChannel	MicroChannel	MicroChannel	MicroChannel
Face Area sq. ft. [sq. m]	1 [25.4]	1 [25.4]	1 [25.4]	1 [25.4]
Rows / FPI [FPcm]	50.8 [4.72]	50.8 [4.72]	50.8 [4.72]	50.8 [4.72]
	1 / 23 [9]	1 / 23 [9]	1 / 23 [9]	1 / 23 [9]
Indoor Coil—Fin Type				
Tube Type	Louvered	Louvered	Louvered	Louvered
Tube Size in. [mm]	Rifled	Rifled	Rifled	Rifled
Face Area sq. ft. [sq. m]	0.375 [9.5]	0.375 [9.5]	0.375 [9.5]	0.375 [9.5]
Rows / FPI [FPcm]	26.67 [2.48]	26.67 [2.48]	26.67 [2.48]	26.67 [2.48]
Refrigerant Control	2 / 18 [7]	2 / 18 [7]	2 / 18 [7]	2 / 18 [7]
Drain Connection No./Size in. [mm]	TX Valves	TX Valves	TX Valves	TX Valves
	1/1 [25.4]	1/1 [25.4]	1/1 [25.4]	1/1 [25.4]
Outdoor Fan—Type				
No. Used/Diameter in. [mm]	Propeller	Propeller	Propeller	Propeller
Drive Type/No. Speeds	3/24 [609.6]	3/24 [609.6]	3/24 [609.6]	3/24 [609.6]
CFM [L/s]	Direct/1	Direct/1	Direct/1	Direct/1
No. Motors/HP	10000 [4719]	10000 [4719]	10000 [4719]	10000 [4719]
Motor RPM	3 at 1/3 HP	3 at 1/3 HP	3 at 1/3 HP	3 at 1/3 HP
	1075	1075	1075	1075
Indoor Fan—Type				
No. Used/Diameter in. [mm]	FC Centrifugal	FC Centrifugal	FC Centrifugal	FC Centrifugal
Drive Type	2/18x9 [457x229]	2/18x9 [457x229]	2/18x9 [457x229]	2/18x9 [457x229]
No. Speeds	Belt (Adjustable)	Belt (Adjustable)	Belt (Adjustable)	Belt (Adjustable)
No. Motors	Single	Single	Single	Single
Motor HP	1	1	1	1
Motor RPM	3	3	5	5
Motor Frame Size	1725	1725	1725	1725
	56	56	184	184
Potable Water Heat Recovery				
Heat Exchanger Type	Vented Double-Wall Flat Plate	Vented Double-Wall Flat Plate	Vented Double-Wall Flat Plate	Vented Double-Wall Flat Plate
Material	Cu Brazed Stainless Steel	Cu Brazed Stainless Steel	Cu Brazed Stainless Steel	Cu Brazed Stainless Steel
No. Flat Plates	50	50	50	50
Unit Water Connections No./Size in. [mm]	2/1.625 [41.3]	2/1.625 [41.3]	2/1.625 [41.3]	2/1.625 [41.3]
Water Pump - Type				
Drive Type/No. Speeds	Centrifugal	Centrifugal	Centrifugal	Centrifugal
Housing Material	Direct/1	Direct/1	Direct/1	Direct/1
GPM [L/s]	Stainless Steel	Stainless Steel	Stainless Steel	Stainless Steel
Head Pressure ft. H2O [kPa]	30 [1.89]	30 [1.89]	30 [1.89]	30 [1.89]
Motor HP	25 [74.7]	25 [74.7]	25 [74.7]	25 [74.7]
Motor RPM	1/3	1/3	1/3	1/3
	3450	3450	3450	3450
Filter - Type				
Furnished	Disposable	Disposable	Disposable	Disposable
(NO.) Size Recommended in. [mm x mm x mm]	Yes	Yes	Yes	Yes
	(8)2x25x20 [51x635x508]	(8)2x25x20 [51x635x508]	(8)2x25x20 [51x635x508]	(8)2x25x20 [51x635x508]
Refrigerant Charge Oz. [g]				
	171/201 [4848/5698]	171/201 [4848/5698]	171/201 [4848/5698]	171/201 [4848/5698]
Weights				
Net Weight lbs. [kg]	2027 [919]	2040 [925]	2056 [933]	2069 [938]
Ship Weight lbs. [kg]	2154 [977]	2167 [983]	2183 [990]	2196 [996]

See Page 19 for Notes.

[] Designates Metric Conversions



NOTES:

1. Cooling Performance is rated at 95° F ambient, 80° F entering dry bulb, 67° F entering wet bulb. Gross capacity does not include the effect of fan motor heat. AHRI capacity is net and includes the effect of fan motor heat. Units are suitable for operation to $\pm 20\%$ of nominal cfm. Units are certified in accordance with the Unitary Air Conditioner Equipment certification program, which is based on AHRI Standard 340/360.
2. EER and/or SEER are rated at AHRI conditions and in accordance with DOE test procedures.
3. Integrated Energy Efficiency Ratio (IEER) is rated in accordance with AHRI Standard 340/360.
4. Heating Performance limit settings and rating data were established and approved under laboratory test conditions using American National Standard Institute standards. Ratings shown are for elevations up to 2000 feet. For elevations above 2000 feet, ratings should be reduced at the rate of 4% for each 1000 feet above sea level.
5. Outdoor Sound Rating shown is tested in accordance with AHRI Standard 270.



GROSS SYSTEMS PERFORMANCE DATA—D180

		ENTERING INDOOR AIR @ 80°F [26.7°C] dbE ①									
wbE		71°F [21.7°C]			67°F [19.4°C]			63°F [17.2°C]			
CFM [L/s]		7200 [3398]	5800 [2737]	4800 [2265]	7200 [3398]	5800 [2737]	4800 [2265]	7200 [3398]	5800 [2737]	4800 [2265]	
DR ①		0.15	0.11	0.07	0.15	0.11	0.07	0.15	0.11	0.07	
OUTDOOR DRY BULB TEMPERATURE °F [°C]	75 [23.9]	Total BTUH [kW] Sens BTUH [kW] Power	222.0 [65.1] 137.7 [40.4] 10.9	212.7 [62.3] 123.8 [36.3] 10.6	206.0 [60.4] 113.8 [33.3] 10.5	210.7 [61.7] 162.8 [47.7] 10.7	201.9 [59.2] 146.4 [42.9] 10.5	195.5 [57.3] 134.6 [39.4] 10.3	205.6 [60.3] 188.7 [55.3] 10.6	197.0 [57.7] 169.6 [49.7] 10.4	190.8 [55.9] 156.0 [45.7] 10.2
	80 [26.7]	Total BTUH [kW] Sens BTUH [kW] Power	216.6 [63.5] 134.6 [39.4] 11.3	207.5 [60.8] 121.0 [35.5] 11.1	201.0 [58.9] 111.3 [32.6] 10.9	205.3 [60.2] 159.8 [46.8] 11.2	196.7 [57.6] 143.6 [42.1] 11.0	190.5 [55.8] 132.0 [38.7] 10.8	200.2 [58.7] 185.7 [54.4] 11.1	191.8 [56.2] 166.9 [48.9] 10.8	185.8 [54.5] 153.4 [45.0] 10.7
	85 [29.4]	Total BTUH [kW] Sens BTUH [kW] Power	211.3 [61.9] 131.6 [38.6] 11.9	202.4 [59.3] 118.3 [34.7] 11.6	196.0 [57.4] 108.8 [31.9] 11.4	200.0 [58.6] 156.8 [45.9] 11.7	191.6 [56.1] 140.9 [41.3] 11.5	185.6 [54.4] 129.6 [38.0] 11.3	194.9 [57.1] 182.7 [53.5] 11.6	186.7 [54.7] 164.2 [48.1] 11.3	180.8 [53.0] 151.0 [44.2] 11.2
	90 [32.2]	Total BTUH [kW] Sens BTUH [kW] Power	205.9 [60.3] 128.7 [37.7] 12.4	197.3 [57.8] 115.7 [33.9] 12.2	191.1 [56.0] 106.4 [31.2] 12.0	194.6 [57.0] 153.9 [45.1] 12.3	186.5 [54.6] 138.3 [40.5] 12.0	180.6 [52.9] 127.2 [37.3] 11.9	189.5 [55.5] 179.8 [52.7] 12.2	181.6 [53.2] 161.6 [47.3] 11.9	175.9 [51.5] 148.6 [43.5] 11.7
	95 [35]	Total BTUH [kW] Sens BTUH [kW] Power	200.6 [58.8] 125.9 [36.9] 13.1	192.2 [56.3] 113.2 [33.2] 12.8	186.1 [54.5] 104.1 [30.5] 12.6	189.3 [55.5] 151.1 [44.3] 12.9	181.4 [53.1] 135.8 [39.8] 12.7	175.7 [51.5] 124.8 [36.6] 12.5	184.2 [54.0] 177.0 [51.9] 12.8	176.5 [51.7] 159.0 [46.6] 12.5	171.0 [50.1] 146.2 [42.9] 12.3
	100 [37.8]	Total BTUH [kW] Sens BTUH [kW] Power	195.3 [57.2] 123.2 [36.1] 13.7	187.1 [54.8] 110.7 [32.4] 13.5	181.2 [53.1] 101.8 [29.8] 13.3	184.0 [53.9] 148.3 [43.5] 13.6	176.3 [51.7] 133.3 [39.1] 13.3	170.8 [50.0] 122.6 [35.9] 13.1	178.9 [52.4] 174.2 [51.1] 13.5	171.4 [50.2] 156.6 [45.9] 13.2	166.0 [48.7] 144.0 [42.2] 13.0
	105 [40.6]	Total BTUH [kW] Sens BTUH [kW] Power	190.0 [55.7] 120.6 [35.3] 14.5	182.0 [53.3] 108.4 [31.8] 14.2	176.3 [51.7] 99.6 [29.2] 14.0	178.7 [52.4] 145.7 [42.7] 14.3	171.2 [50.2] 131.0 [38.4] 14.0	165.9 [48.6] 120.4 [35.3] 13.8	173.7 [50.9] 171.6 [50.3] 14.2	166.4 [48.7] 154.2 [45.2] 13.9	161.1 [47.2] 141.8 [41.6] 13.7
	110 [43.3]	Total BTUH [kW] Sens BTUH [kW] Power	184.8 [54.1] 118.0 [34.6] 15.3	177.0 [51.9] 106.1 [31.1] 14.9	171.5 [50.2] 97.6 [28.6] 14.7	173.5 [50.8] 143.2 [42.0] 15.1	166.2 [48.7] 128.7 [37.7] 14.8	161.0 [47.2] 118.3 [34.7] 14.6	168.4 [49.3] 168.4 [49.3] 15.0	161.3 [47.3] 152.0 [44.5] 14.7	156.3 [45.8] 139.7 [40.9] 14.5
	115 [46.1]	Total BTUH [kW] Sens BTUH [kW] Power	179.5 [52.6] 115.6 [33.9] 16.1	172.0 [50.4] 103.9 [30.4] 15.8	166.6 [48.8] 95.5 [28.0] 15.5	168.2 [49.3] 140.7 [41.2] 16.0	161.2 [47.2] 126.5 [37.1] 15.6	156.1 [45.8] 116.3 [34.1] 15.4	163.2 [47.8] 163.2 [47.8] 15.8	156.3 [45.8] 149.8 [43.9] 15.5	151.4 [44.4] 137.7 [40.4] 15.3
	120 [48.9]	Total BTUH [kW] Sens BTUH [kW] Power	174.3 [51.1] 113.3 [33.2] 17.0	167.0 [48.9] 101.8 [29.8] 16.6	161.8 [47.4] 93.6 [27.4] 16.4	163.0 [47.8] 138.4 [40.6] 16.9	156.2 [45.8] 124.4 [36.4] 16.5	151.3 [44.3] 114.4 [33.5] 16.3	157.9 [46.3] 157.9 [46.3] 16.7	151.3 [44.3] 147.7 [43.3] 16.4	146.6 [42.9] 135.8 [39.8] 16.1
	125 [51.7]	Total BTUH [kW] Sens BTUH [kW] Power	169.1 [49.6] 111.0 [32.5] 17.9	162.0 [47.5] 99.8 [29.2] 17.6	156.9 [46.0] 91.7 [26.9] 17.3	157.8 [46.3] 136.1 [39.9] 17.8	151.2 [44.3] 122.4 [35.9] 17.4	146.5 [42.9] 112.5 [33.0] 17.2	152.8 [44.8] 152.8 [44.8] 17.7	146.3 [42.9] 145.6 [42.7] 17.3	141.7 [41.5] 133.9 [39.2] 17.0

DR —Depression ratio
dbE —Entering air dry bulb
wbE—Entering air wet bulb

Total —Total capacity x 1000 BTUH
Sens —Sensible capacity x 1000 BTUH
Power —KW input

NOTES: ① When the entering air dry bulb is other than 80°F [27°C], adjust the sensible capacity from the table by adding [1.10 x CFM x (1 – DR) x (dbE – 80)].





GROSS WATER HEATING CAPACITY—D180

		ENTERING INDOOR AIR @ 80°F [26.7°C] dbE									
wbE		71°F [15.5°C]			67°F [19.4°C]			63°F [19.4°C]			
CFM [L/s]		7200 [3398]	5800 [2737]	4800 [2265]	7200 [3398]	5800 [2737]	4800 [2265]	7200 [3398]	5800 [2737]	4800 [2265]	
O U T L E T W A T E R T E M P E R A T U R E °F [°C]	75 [23.9]	Total BTUH [kW] Power	145.0 [42.5] 4.2	142.9 [41.9] 4.2	140.3 [41.1] 4.4	140.9 [41.3] 4.2	132.3 [38.8] 5.9	131.9 [38.7] 4.3	141.4 [41.4] 4.2	134.6 [39.4] 4.5	129.3 [37.9] 4.2
	80 [26.7]	Total BTUH [kW] Power	142.8 [41.9] 4.4	140.8 [41.3] 4.4	138.7 [40.6] 4.5	139.0 [40.7] 4.4	130.9 [38.4] 5.7	130.4 [38.2] 4.4	139.5 [40.9] 4.4	133.2 [39.0] 4.7	128.2 [37.6] 4.4
	85 [29.4]	Total BTUH [kW] Power	140.7 [41.2] 4.6	138.7 [40.6] 4.6	137.1 [40.2] 4.7	137.2 [40.2] 4.6	129.4 [37.9] 5.5	128.9 [37.8] 4.6	137.5 [40.3] 4.6	131.8 [38.6] 4.9	127.0 [37.2] 4.6
	90 [32.2]	Total BTUH [kW] Power	138.5 [40.6] 4.8	136.6 [40.0] 4.8	135.5 [39.7] 4.9	135.3 [39.7] 4.8	128.0 [37.5] 5.5	127.4 [37.3] 4.8	135.6 [39.7] 4.8	130.3 [38.2] 5.2	125.9 [36.9] 4.8
	95 [35.0]	Total BTUH [kW] Power	136.4 [40.0] 5.1	134.4 [39.4] 5.1	133.9 [39.2] 5.2	133.4 [39.1] 5.1	126.5 [37.1] 5.5	126.0 [36.9] 5.1	133.7 [39.2] 5.1	128.9 [37.8] 5.4	124.7 [36.5] 5.1
	100 [37.8]	Total BTUH [kW] Power	134.3 [39.4] 5.4	132.3 [38.8] 5.3	132.4 [38.8] 5.4	131.5 [38.5] 5.4	125.1 [36.7] 5.7	124.5 [36.5] 5.4	131.7 [38.6] 5.4	127.5 [37.4] 5.7	123.6 [36.2] 5.4
	105 [40.6]	Total BTUH [kW] Power	132.1 [38.7] 5.7	130.2 [38.2] 5.7	130.8 [38.3] 5.7	129.7 [38.0] 5.7	123.6 [36.2] 6.0	123.0 [36.0] 5.7	129.8 [38.0] 5.7	126.1 [37.0] 6.0	122.4 [35.9] 5.7
	110 [43.3]	Total BTUH [kW] Power	130.0 [38.1] 6.0	128.1 [37.5] 6.0	129.2 [37.9] 6.0	127.8 [37.5] 6.0	122.2 [35.8] 6.3	121.6 [35.6] 6.0	127.9 [37.5] 6.0	124.7 [36.5] 6.4	121.3 [35.5] 6.0
	115 [46.1]	Total BTUH [kW] Power	127.9 [37.5] 6.4	126.0 [36.9] 6.4	127.6 [37.4] 6.4	125.9 [36.9] 6.4	120.7 [35.4] 6.6	120.1 [35.2] 6.4	125.9 [36.9] 6.4	123.3 [36.1] 6.8	120.1 [35.2] 6.4
	120 [48.9]	Total BTUH [kW] Power	125.7 [36.8] 6.8	123.8 [36.3] 6.8	126.0 [36.9] 6.8	124.1 [36.4] 6.8	119.3 [35.0] 7.1	118.6 [34.8] 6.8	124.0 [36.3] 6.8	121.9 [35.7] 7.2	119.0 [34.9] 6.8
	125 [51.7]	Total BTUH [kW] Power	123.6 [36.2] 7.3	121.7 [35.7] 7.3	124.4 [36.5] 7.2	122.2 [35.8] 7.3	117.8 [34.5] 7.5	117.2 [34.3] 7.3	122.1 [35.8] 7.3	120.5 [35.3] 7.7	117.8 [34.5] 7.3

DR —Depression ratio
dbE—Entering air dry bulb
wbE—Entering air wet bulb

Total —Total capacity x 1000 BTUH
Power—KW input

NOTES: ① When the entering air dry bulb is other than 80°F [27°C], adjust the sensible capacity from the table by adding $[1.10 \times \text{CFM} \times (1 - \text{DR}) \times (\text{dbE} - 80)]$.

GROSS WATTS 2ND STAGE kW ADD FOR MIXED MODE OPERATION—D180

		ENTERING INDOOR AIR @ 80°F [26.7°C] dbE								
wbE		71°F [15.5°C]			67°F [19.4°C]			63°F [19.4°C]		
CFM [L/s]		7200 [3398]	5800 [2737]	4800 [2265]	7200 [3398]	5800 [2737]	4800 [2265]	7200 [3398]	5800 [2737]	4800 [2265]
O U T D O O R D R Y B U L B T E M P E R A T U R E °F [°C]	75 [23.9]	5.9	5.8	5.7	5.8	5.7	5.6	5.8	5.6	5.6
	80 [26.7]	6.1	6.0	5.9	6.1	5.9	5.8	6.0	5.9	5.8
	85 [29.4]	6.4	6.2	6.1	6.3	6.2	6.1	6.2	6.1	6.0
	90 [32.2]	6.6	6.5	6.4	6.6	6.4	6.3	6.5	6.4	6.3
	95 [35.0]	6.9	6.8	6.7	6.9	6.7	6.6	6.8	6.6	6.5
	100 [37.8]	7.3	7.1	7.0	7.2	7.0	6.9	7.1	7.0	6.9
	105 [40.6]	7.6	7.5	7.4	7.5	7.4	7.3	7.5	7.3	7.2
	110 [43.3]	8.0	7.8	7.7	7.9	7.8	7.6	7.8	7.7	7.6
	115 [46.1]	8.4	8.2	8.1	8.3	8.2	8.0	8.3	8.1	8.0
	120 [48.9]	8.9	8.7	8.5	8.8	8.6	8.5	8.7	8.5	8.4
	125 [51.7]	9.3	9.1	9.0	9.2	9.1	8.9	9.2	9.0	8.8

The Kw values in the table are added to the water heating watt values when unit is operating in a mixed mode operation (first stage providing water heating, second stage in cooling mode).

[] Designates Metric Conversions



AIRFLOW PERFORMANCE—15 TON [52.8 kW]—60 HZ — DOWNFLOW

Air Flow CFM [L/s]	Model RKHL-D180 Voltage 208/230, 460 — 3 Phase 60 Hz																			
	External Static Pressure—Inches of Water [kPa]																			
	0.1 [.02]	0.2 [.05]	0.3 [.07]	0.4 [.10]	0.5 [.12]	0.6 [.15]	0.7 [.17]	0.8 [.20]	0.9 [.22]	1.0 [.25]	1.1 [.27]	1.2 [.30]	1.3 [.32]	1.4 [.35]	1.5 [.37]	1.6 [.40]	1.7 [.42]	1.8 [.45]	1.9 [.47]	2.0 [.50]
4800 [2265]	—	—	—	—	—	—	—	—	—	—	—	—	—	—	—	—	—	—	—	—
5000 [2359]	—	—	—	—	—	—	—	—	—	—	—	—	—	—	—	—	—	—	—	—
5200 [2454]	—	—	—	—	—	—	—	—	—	—	—	—	—	—	—	—	—	—	—	—
5400 [2548]	—	—	—	—	—	—	—	—	—	—	—	—	—	—	—	—	—	—	—	—
5600 [2643]	—	—	—	—	—	—	—	—	—	—	—	—	—	—	—	—	—	—	—	—
5800 [2737]	—	—	—	—	—	—	—	—	—	—	—	—	—	—	—	—	—	—	—	—
6000 [2831]	—	—	—	—	—	—	—	—	—	—	—	—	—	—	—	—	—	—	—	—
6200 [2926]	—	—	—	—	—	—	—	—	—	—	—	—	—	—	—	—	—	—	—	—
6400 [3020]	—	—	—	—	—	—	—	—	—	—	—	—	—	—	—	—	—	—	—	—
6600 [3114]	—	—	—	—	—	—	—	—	—	—	—	—	—	—	—	—	—	—	—	—
6800 [3209]	577	1878	603	1984	628	2098	652	2219	677	2347	700	2483	724	2627	747	2778	769	2937	791	3104
7000 [3303]	591	2023	616	2131	641	2246	665	2368	689	2499	712	2636	735	2782	757	2935	779	3095	801	3263
7200 [3398]	606	2177	630	2286	654	2402	678	2527	701	2659	724	2798	746	2945	768	3099	790	3262	811	3431

NOTE: L-Drive left of bold line, M-Drive right of bold line.

Drive Package	L						M					
Motor H.P. [W]	3 [2237.1]						5 [2237.1]					
Blower Sheave	BK105H						BK105H					
Motor Sheave	1VP-44						1VP-56					
Turns Open	1	2	3	4	5	6	1	2	3	4	5	6
RPM	732	701	670	642	608	575	896	866	836	805	774	744

- NOTES: 1. Factory sheave settings are shown in bold type.
 2. Do not set motor sheave below minimum or maximum turns open shown.
 3. Re-adjustment of sheave required to achieve rated airflow at AHRI minimum External Static Pressure
 4. Add component resistance (below) to duct resistance to determine total External Static Pressure.

Airflow CFM [L/s]	AIRFLOW CORRECTION FACTORS*						Wet Coil			Downflow Economizer RA Damper Open			Concentric Grill RXRN-AD80 or RXRN-AD81 & Transition RXMC-CJ07			Concentric Grill RXRN-AD86 & Transition RXMC-CK08		
	Total MBH	Sensible MBH		Power kW		Resistance — Inches of Water [kPa]	Resistance — Inches of Water [kPa]			Resistance — Inches of Water [kPa]			Resistance — Inches of Water [kPa]					
4800 [2265]	0.97	0.92		0.98		0.03 [.01]	0.09 [.02]			—			—					
5000 [2359]	0.97	0.94		0.99		0.04 [.01]	0.10 [.02]			—			—					
5200 [2454]	0.98	0.95		0.99		0.05 [.01]	0.10 [.02]			—			—					
5400 [2548]	0.99	0.97		0.99		0.06 [.01]	0.11 [.03]			—			—					
5600 [2643]	0.99	0.98		0.99		0.06 [.01]	0.12 [.03]			0.35 [.09]			—					
5800 [2737]	1.00	1.00		1.00		0.07 [.02]	0.13 [.03]			0.39 [.10]			—					
6000 [2831]	1.01	1.02		1.00		0.08 [.02]	0.13 [.03]			0.43 [.11]			—					
6200 [2926]	1.01	1.03		1.00		0.09 [.02]	0.14 [.03]			0.46 [.11]			—					
6400 [3020]	1.02	1.05		1.01		0.10 [.02]	0.15 [.04]			0.50 [.12]			—					
6600 [3114]	1.02	1.06		1.01		0.10 [.02]	0.16 [.04]			0.54 [.13]			—					
6800 [3209]	1.03	1.08		1.01		0.11 [.03]	0.16 [.04]			—			—					
7000 [3303]	1.04	1.10		1.01		0.12 [.03]	0.17 [.04]			—			—					
7200 [3398]	1.04	1.11		1.02		0.13 [.03]	0.18 [.04]			—			0.38 [.09]					

*Multiply correction factor times gross performance data — resulting sensible capacity cannot exceed total capacity. [] Designates Metric Conversions

ELECTRICAL DATA – RKHL- SERIES					
		D180CL	D180CM	D180DL	D180DM
Unit Information	Unit Operating Voltage Range	187-253	187-253	414-506	414-506
	Volts	208/230	208/230	460	460
	Minimum Circuit Ampacity	77/77	81/81	40	42
	Minimum Overcurrent Protection Device Size	90/90	90/90	45	45
	Maximum Overcurrent Protection Device Size	100/100	100/100	50	50
Compressor Motor	No.	2	2	2	2
	Volts	200/230	200/230	460	460
	Phase	3	3	3	3
	RPM	3450	3450	3450	3450
	HP, Compressor 1	7 1/2	7 1/2	7 1/2	7 1/2
	Amps (RLA), Comp. 1	25/25	25/25	12.8	12.8
	Amps (LRA), Comp. 1	164/164	164/164	100	100
	HP, Compressor 2	7 1/2	7 1/2	7 1/2	7 1/2
	Amps (RLA), Comp. 2	25/25	25/25	12.8	12.8
	Amps (LRA), Comp. 2	164/164	164/164	100	100
Condenser Motor	No.	3	3	3	3
	Volts	208/230	208/230	460	460
	Phase	1	1	1	1
	HP	1/3	1/3	1/3	1/3
	Amps (FLA, each)	2.4/2.4	2.4/2.4	1.4	1.4
	Amps (LRA, each)	4.7/4.7	4.7/4.7	2.4	2.4
Evaporator Fan	No.	1	1	1	1
	Volts	208/230	208/230	460	460
	Phase	3	3	3	3
	HP	3	5	3	5
	Amps (FLA, each)	11.5/11.5	14.9/14.9	4.6	6.6
	Amps (LRA, each)	74.5/74.5	95/95	38.1	47.5
Water Pump	No.	1	1	1	1
	Volts	208/230	208/230	208/230	208/230
	Phase	1	1	1	1
	HP	1/3	1/3	1/3	1/3
	Amps (FLA, each)	1.7	1.7	1.7	1.7
	Amps (LRA, each)	5.1	5.1	5.1	5.1

GAS HEAT / ELECTRIC COOLING PACKAGE DOWNFLOW ONLY

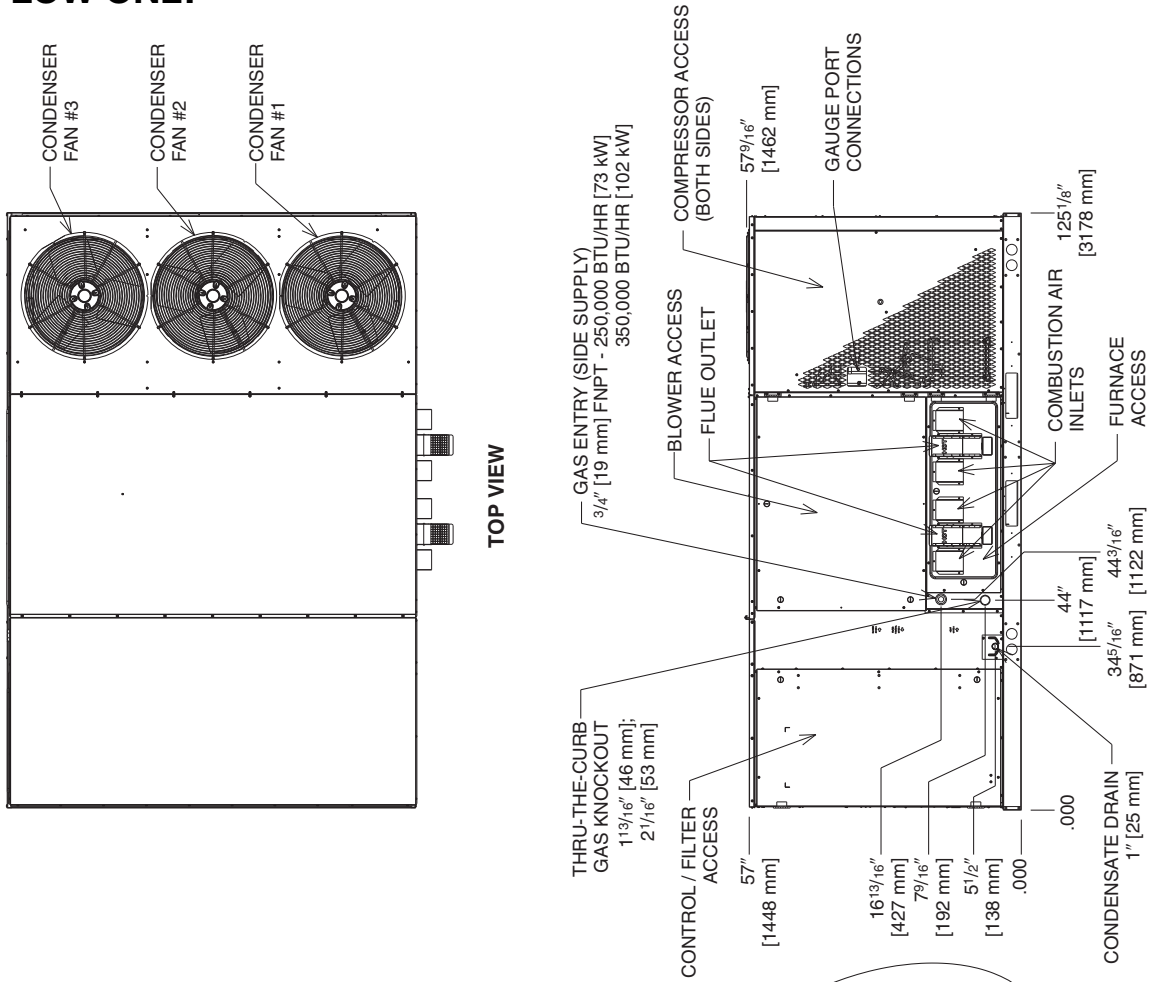

FRONT VIEW

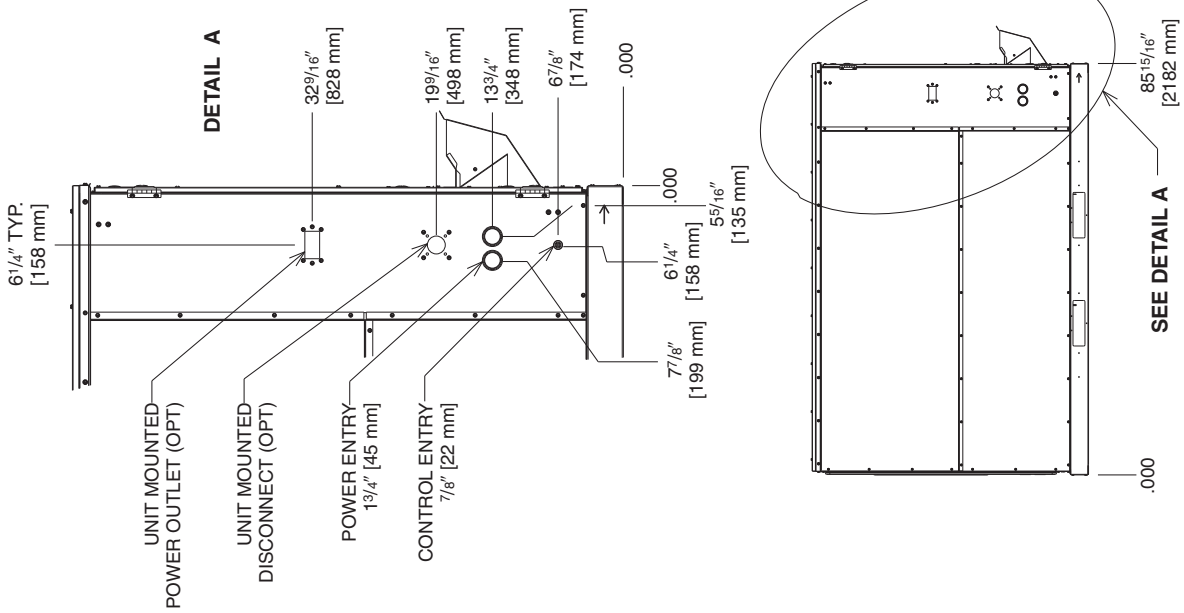

LEFT VIEW

[] Designates Metric Conversions

Illustration
ST-A1207-07

GAS HEAT / ELECTRIC COOLING PACKAGE DOWNFLOW ONLY

BOTTOM VIEW

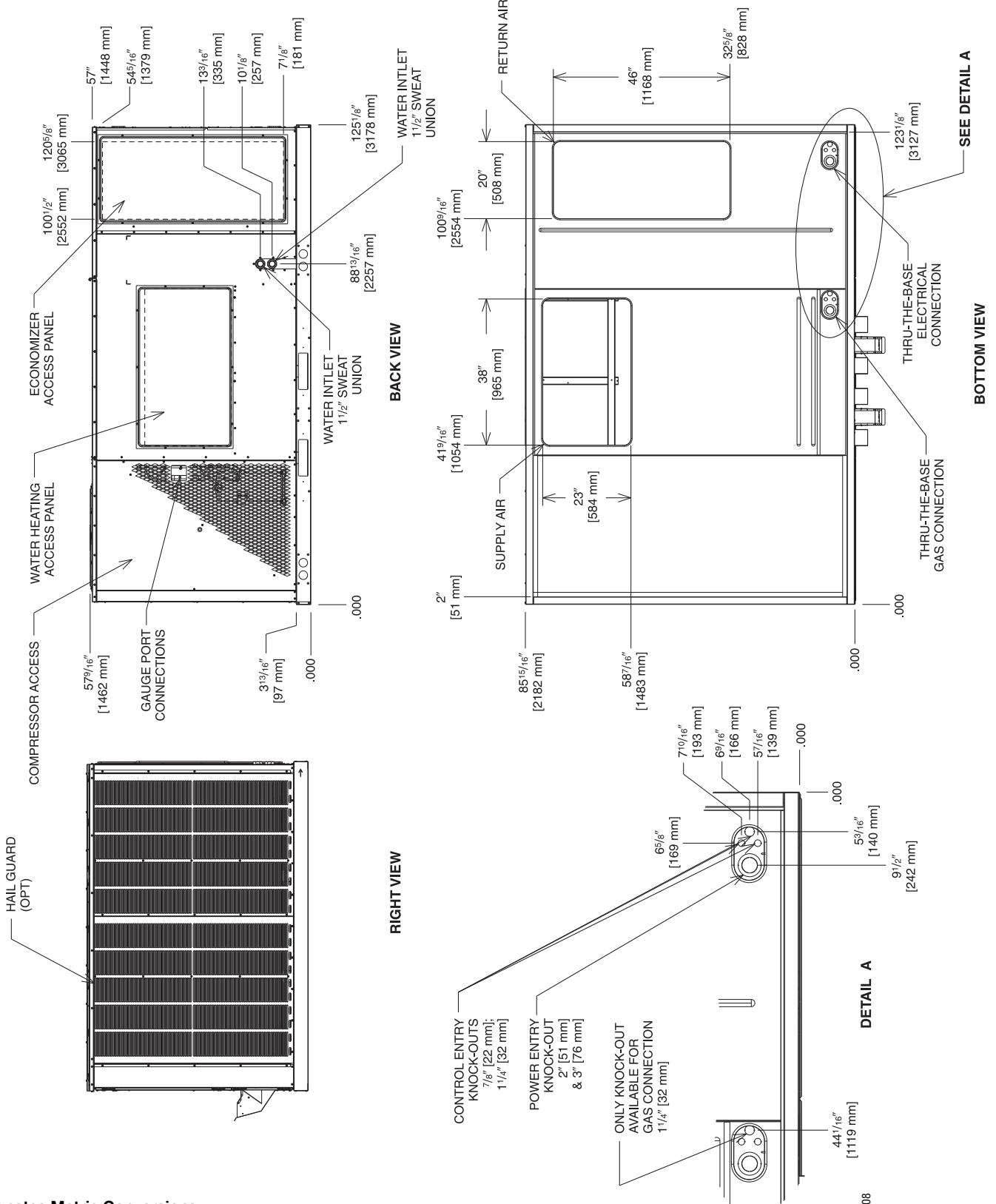

[] Designates Metric Conversions

Illustration
ST-A1207-08

WEIGHTS

Accessory	Shipping—lbs [kg]	Operating—lbs [kg]
Economizer	277 [125.8]	168 [76.2]
Power Exhaust	119 [54.0]	59 [26.8]
Manual Fresh Air Damper	61 [27.7]	52 [23.6]
Motor Kit for Fresh Air Damper	42 [19.1]	35 [15.9]
Roof Curb 14"	184 [83.5]	176 [79.8]
Hail Guard Louvers	55 [24.8]	45 [20.3]

Capacity Tons [kW]	Corner Weights by Percentage			
	A	B	C	D
15 [52.8]	26%	29%	18%	27%

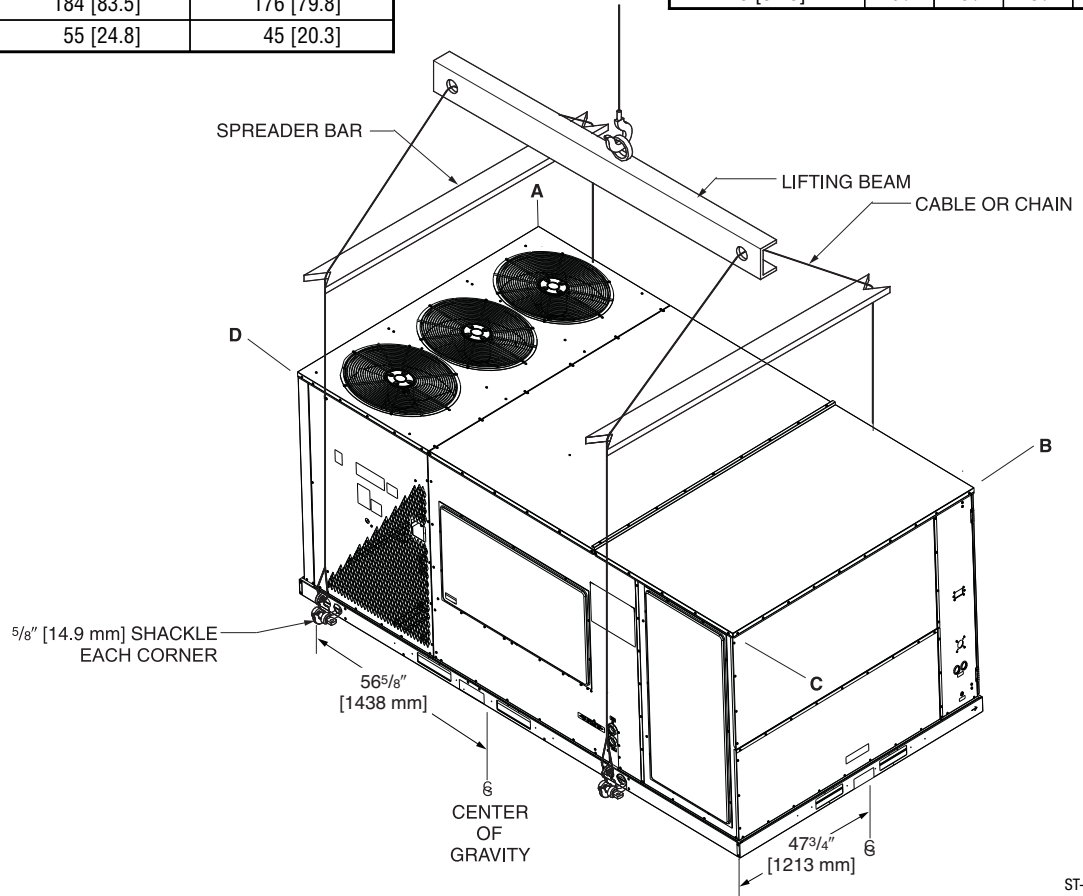
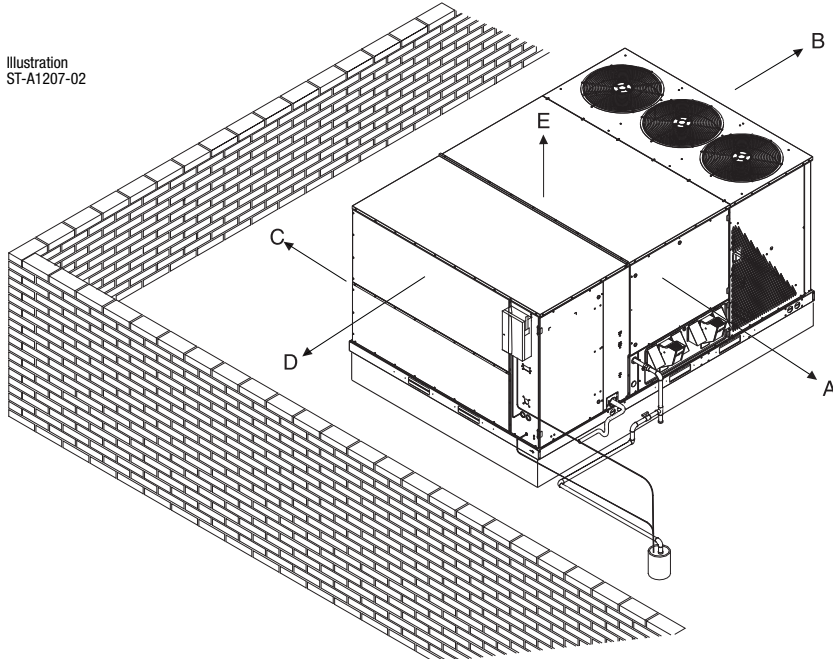

Illustration
ST-A1207-25

Illustration
ST-A1207-02



CLEARANCES

The following minimum clearances must be observed for proper unit performance and serviceability.

Recommended Clearance In. [mm]	Location
80 [2032]	A - Front
18 [457]	B - Condenser Coil
18 [457]	C - Back
18 [457]*	D - Evaporator End
60 [1524]	E - Above
*Without Economizer. 48" [1219 mm] With Economizer	

[] Designates Metric Conversions

FIELD INSTALLED ACCESSORY EQUIPMENT

Accessory	Model Number	Shipping Weight Lbs. [kg]	Installed Weight Lbs. [kg]	Factory Weight Available?
Thermostats	See Thermostat Specification Sheet for Details (T11-001)			No
Economizer - Single Enthalpy (DDC)	AXRD-PMCM3	277 [125.6]	168 [76.2]	Yes
Dual Enthalpy Kit (DDC)	RXXR-AV03	1 [.5]	1 [.5]	No
Economizer-Single Enth/ Smoke Detector (DDC)	AXRD-SMCM3	280 [127.0]	171 [77.6]	Yes
Carbon Dioxide Sensor (Wall Mount)	RXXR-AR02	3 [1.4]	2 [1.0]	No
Power Exhaust (208/230V)	RXXR-BGF05C	119 [54.0]	59 [26.8]	No
Power Exhaust (460V)	RXXR-BGF05D	119 [54.0]	59 [26.8]	No
Manual Fresh Air Damper*	AXRF-KFA1	61 [27.7]	52 [23.6]	No
Motor Kit for AXRF-KFA1 Fresh Air Damper	RXXR-AW03	42 [19.1]	35 [15.9]	No
Modulating Mtr Kit w/ Feedback for RXRF-KFA1*	RXXR-AW05	45 [20.4]	38 [17.2]	No
Roofcurb, 14"	RXKG-CBH14	184 [83.5]	176 [79.8]	No
Roofcurb Adapter to RXRK-E56	RXXR-CJCE56	465 [210.9]	415 [88.2]	No
Roofcurb Adapter to RXKG-CAF14	RXXR-CJCF14	555 [251.7]	505 [29.1]	No
Concentric Diffuser (Step-Down, 18" x 36")	RXRN-AD81	310 [140.6]	157 [71.2]	No
Concentric Diffuser (Flush, 18" x 36")	RXRN-AD80	213 [96.6]	115 [52.2]	No
Downflow Transition (Rect. to Rect., 18" x 36")	RXMC-CJ07	81 [36.7]	74 [33.6]	No
Low-Ambient Control Kit (1 Per Compressor)	RXRZ-C02	3 [1.4]	2 [1.0]	Yes
Unwired Convenience Outlet	RXXR-AN01	2 [1.0]	1.5 [.7]	Yes
Unfused Service Disconnect	RXXR-AP01	10 [4.5]	9 [4.1]	Yes
Comfort Alert (1 Per Compressor)	RXXR-AZ01	3 [1.5]	2 [0.9]	Yes
BACnet Communication Card	RXXR-AY01	1 [0.5]	1 [0.5]	No
LonWorks Communication Card	RXXR-AY02	1 [0.5]	1 [0.5]	No
Hail Guard Louvers	AXRX-AAD01K	55 [24.8]	45 [20.3]	Yes
Commercial Storage Tank	ST120	300 [136.1]	1240 [562.5]	No
Flush valve kit for eSYNC™ Unit	RXMV-AG	12 [5.4]	11 [5.0]	No
Emergency Electrically Operated Water Shutoff Valve	RXMV-AH	12 [5.4]	11 [5.0]	No
Water Storage Tank Kit	RXMZ-A120A	32 [14.5]	30 [13.6]	No

*Motorized Kit and Manual Fresh Air Damper must be combined for a complete Motorized Outside Air Damper Selection.

NOTICE: Please refer to conversion kit index provided with the unit for LP conversion kit.

[] Designates Metric Conversions

THERMOSTATS



200-Series *
 Programmable



300-Series *
 Deluxe Programmable

400-Series *
 Special Applications/
 Programmable



500-Series *
 Communicating/
 Programmable

Brand	Descriptor (3 Characters)	Series (3 Characters)	System (2 Characters)	Type (2 Characters)
RHC	- TST	213	UN	MS
RHC=Rheem	TST=Thermostat	200=Programmable 300=Deluxe Programmable 400=Special Applications/ Programmable 500=Communicating/ Programmable	GE=Gas/Electric UN=Universal (AC/HP/GE) MD=Modulating Furnace DF=Dual Fuel CM=Communicating	SS=Single-Stage MS=Multi-Stage

* Photos are representative. Actual models may vary.

For detailed thermostat match-up information,
 see specification sheet form number T11-001.

FLUSH MOUNT ROOM TEMPERATURE SENSORS FOR NETWORKED DDC APPLICATIONS



ROOM TEMPERATURE SENSOR RHC-ZNS1 with TIMED OVERRIDE BUTTON

10kΩ room temperature sensor transmits room temperature to DDC system. Timed override button allows tenant to change from unoccupied temperature setpoint to occupied temperature setpoint for a preset time.



ROOM TEMPERATURE SENSOR RHC-ZNS2 with TIMED OVERRIDE BUTTON and STATUS INDICATOR

10kΩ room temperature sensor transmits room temperature to DDC system. Timed override button allows tenant to change from unoccupied temperature setpoint to occupied temperature setpoint for a preset time. Status Indicator Light transmits ALARM flash code to occupied space.



ROOM TEMPERATURE SENSOR RHC-ZNS3 with SETPOINT ADJUSTMENT and TIMED OVERRIDE BUTTON

10kΩ room temperature sensor with setpoint adjustment transmits room temperature to DDC system along with desired occupied room temperature setpoint. Timed override button allows tenant to change from unoccupied temperature setpoint to occupied temperature setpoint for a preset time.

COMMUNICATION CARDS Field Installed



BACnet® COMMUNICATION CARD RXRX-AY01

The field installed BACnet® Communication Card allows the RTU-C unit controller to communicate with a third party building management system that supports the BACnet Application Specific Controller device profile. The BACnet® Communication Module plugs onto the unit RTU-C controller and allows communication between the RTU-C and the BACnet MSTP network.



LonWorks® COMMUNICATION CARD RXRX-AY02

The field installed LonWorks® Communication Card allows the RTU-C unit controller to communicate with a third party building management system that supports the LonMark Space Comfort Controller (SCC) functional profile or LonMark Discharge Air Controller (DAC) functional profile. The LonMark Communication Module plugs onto the RTU-C controller and allows communication between the RTU-C and a LonWorks Network.

ECONOMIZERS

Use to Select Factory Installed Options Only

AXRD-PMCM3—Single Enthalpy (Outdoor) with DDC

AXRD-SMCM3—Single Enthalpy (Outdoor) with Smoke Detector and DDC

RXX-AR02—Optional Wall-Mounted CO₂ Sensor

- Features **Honeywell Controls**
- Available Factory Installed or Field Accessory
- Gear Driven Direct Drive Actuator
- Fully Modulating (0-100%)
- Low Leakage Dampers
- Slip-In Design for Easy Installation
- Plug-In Polarized 12-pin and 4-pin Electrical Connections
- Pre-Configured—No Field Adjustments Necessary
- Standard Barometric Relief Damper
- Single Enthalpy with Dual Enthalpy Upgrade Kit Available
- CO₂ Input Sensor Available
- Field Assembled Hood Ships with Economizer
- Economizer Ships Complete for Downflow Duct Application.
- Optional Remote Minimum Position Potentiometer (270 ohm) (Honeywell #S963B1136) is available from Prostock.
- Field Installed Power Exhaust Available
- If connected to a Building Automation System (BAS), all economizer functions can be viewed on the (BAS) or 16 x 2 LCD screen
- If connected to thermostat, all economizer functions can be viewed on 16 x 2 character LCD screen

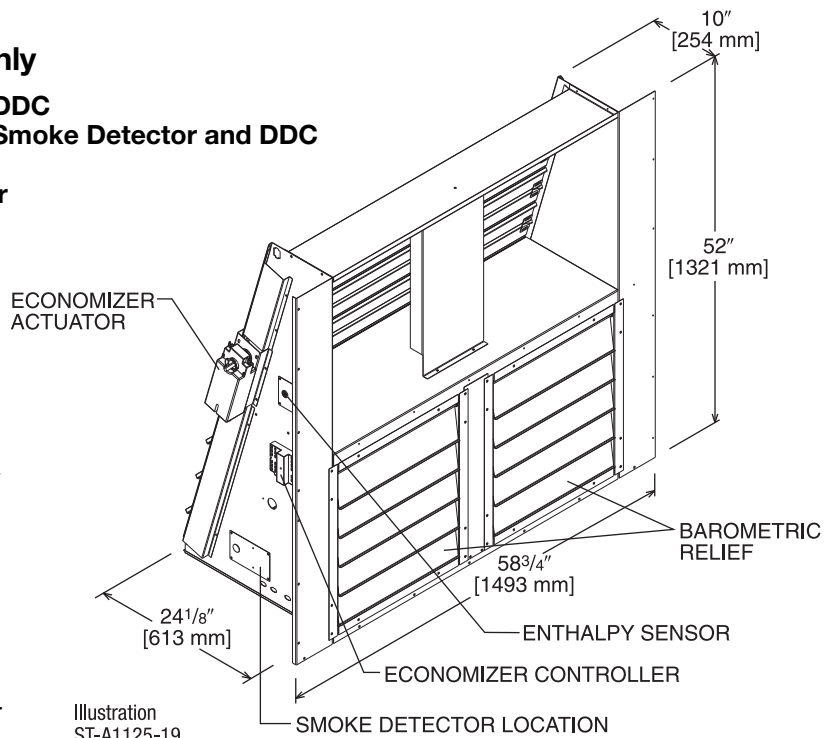

Illustration
ST-A1125-19

TOLERANCE ±.125

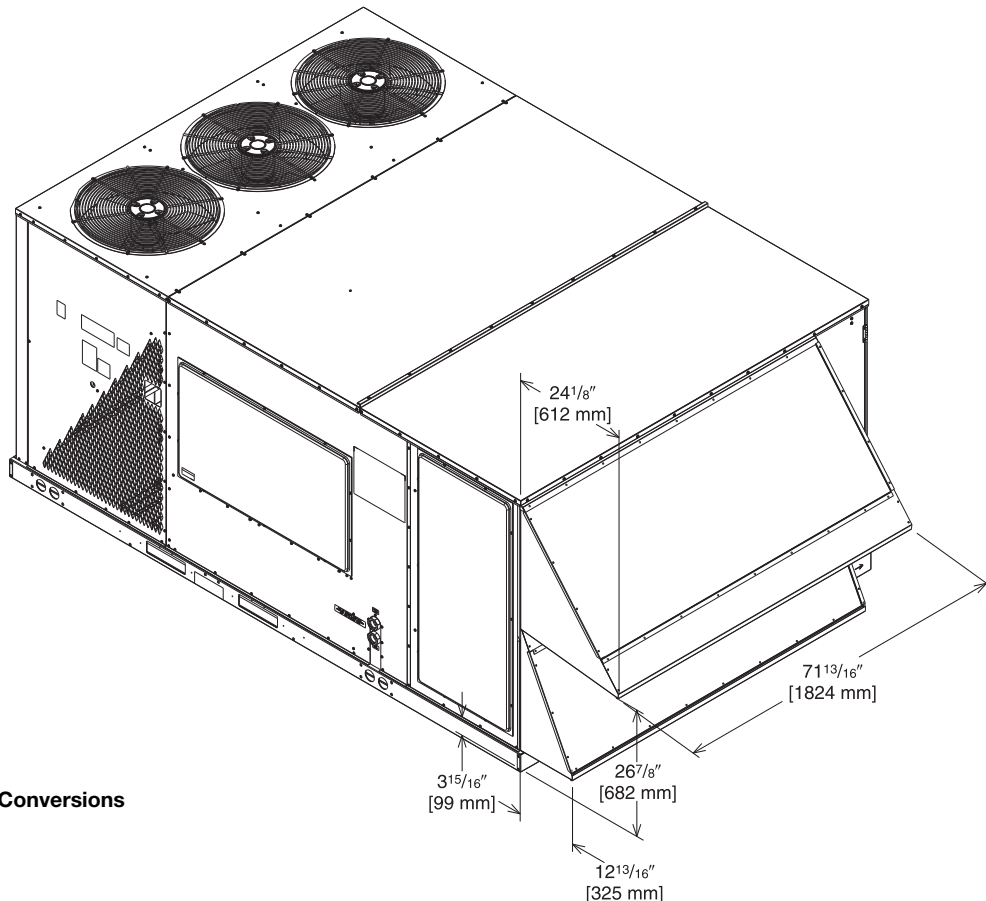

Illustration
ST-A1207-21

[] Designates Metric Conversions

POWER EXHAUST KIT FOR AXRD-PMCM3 & SMCM3 ECONOMIZERS

RXRX-BGF05 (C or D*)

*Voltage Code

VERTICAL AIRFLOW

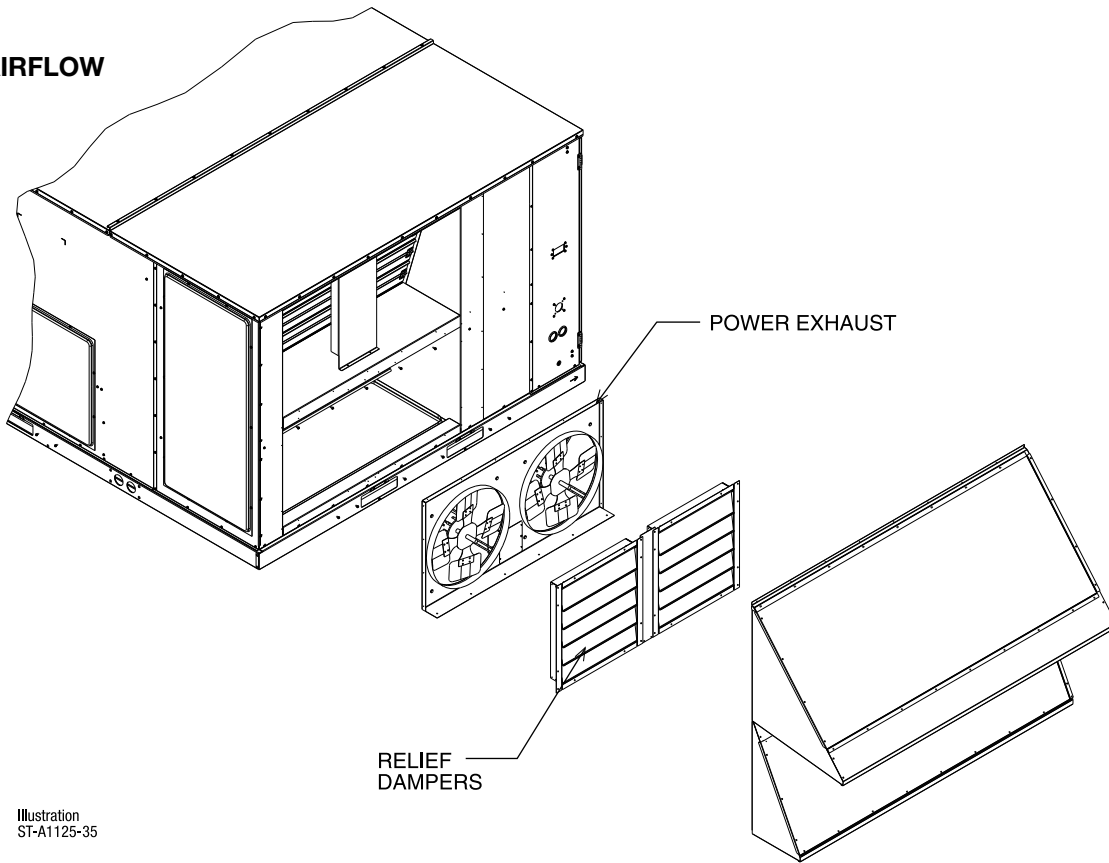

Model No.	No. of Fans	Volts	Phase	HP (ea.)	Low Speed		High Speed ①		FLA (ea.)	LRA (ea.)
					CFM [L/s] ②	RPM	CFM [L/s] ②	RPM		
RXRX-BGF05C	2	208-230	1	0.75	4100 [1935]	850	5200 [2454]	1050	5	4.97
RXRX-BGF05D	2	460	1	0.75	4100 [1935]	850	5200 [2454]	1050	2.2	3.4

NOTES: ① Power exhaust is factory set on high speed motor tap.
② CFM is per fan at 0" w.c. external static pressure.

[] Designates Metric Conversions

FRESH AIR DAMPER

MOTORIZED DAMPER KIT

RXRX-AW03

(Motor Kit for AXRF-KFA1)

RXRX-AW05

(Modulating Motor Kit with position feedback for AXRF-KFA1)

- Features **Honeywell** Controls
- Gear Driven Direct Drive Actuator
- Fully Modulating (0-100%)
- Low Leakage Dampers
- Slip-In Design for Easy Installation
- Plug-In Polarized 12-pin and 4-pin Electrical Connections
- Pre-Configured—No Field Adjustments Necessary
- Addition of Dual Enthalpy Upgrade Kit allows limited economizer function
- CO₂ Sensor Input Available for Demand Control Ventilation (DCV)
- Optional Remote Minimum Position Potentiometer (270 ohm) (Honeywell #S963B1136) is available from Prostock.
- All fresh air damper functions can be viewed at the RTU-C unit controller display
- If connected to a Building Automation System (BAS), all fresh air damper functions can be viewed on the (BAS), on 16 x 2 LCD screen
- If connected to thermostat, all fresh air damper functions can be viewed on 16 x 2 LCD screen

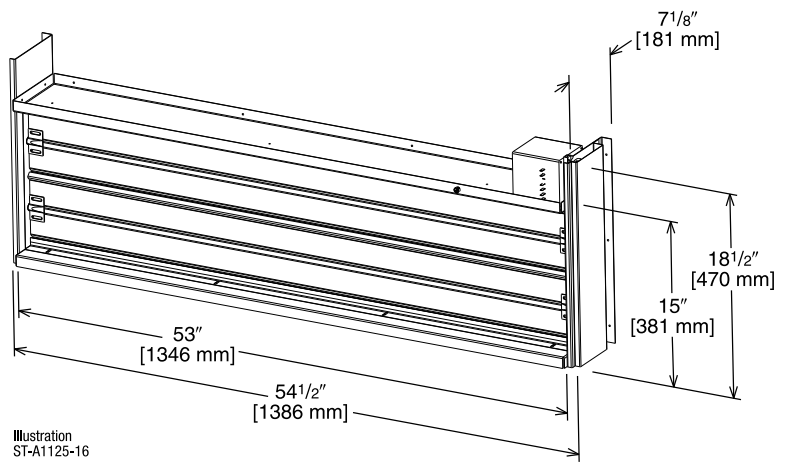

AXRF-KFA1 (Manual)

RXRX-AW03 (Motorized damper kit for manual fresh air damper)

RXRX-AW05 (Modulating damper kit with position feedback for AXRF-KFA1)

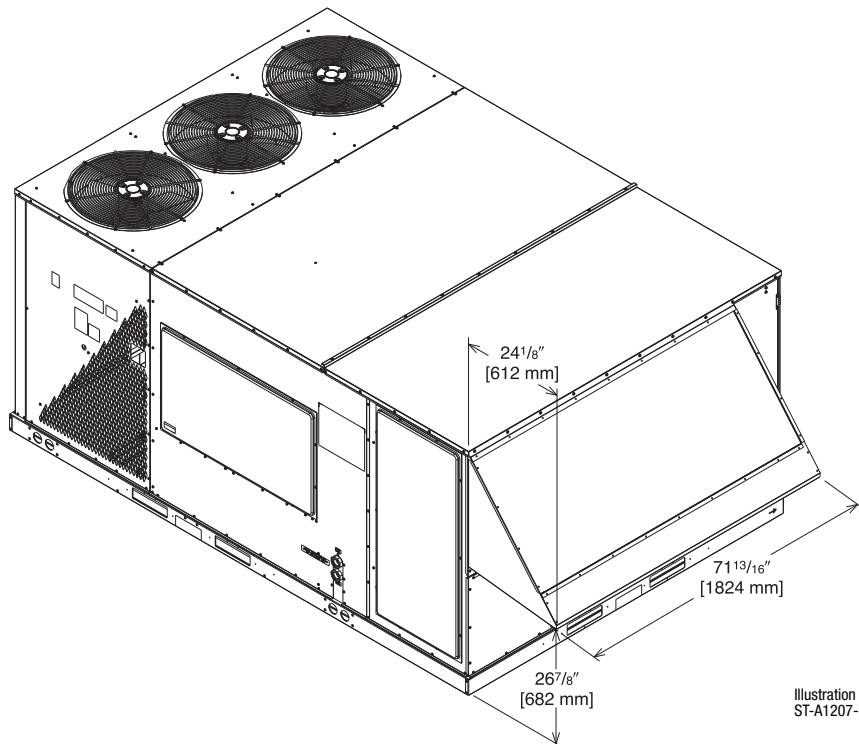

[] Designates Metric Conversions

ROOFCURBS (Full Perimeter)

- Rheem's new roofcurb designs can be utilized on 15, 17.5, 20 and 25 ton [52.8, 61.5, 70.3 and 70.3 kW] models.
- One available height (14" [356 mm]).
- Quick assembly corners for simple and fast assembly.
- 1" [25.4 mm] x 4" [102 mm] Nailers provided.
- Insulating panels not required because of insulated outdoor base pan.
- Sealing gasket (28" [711 mm]) provided with Roofcurb.
- Packaged for easy field assembly.

TYPICAL INSTALLATION

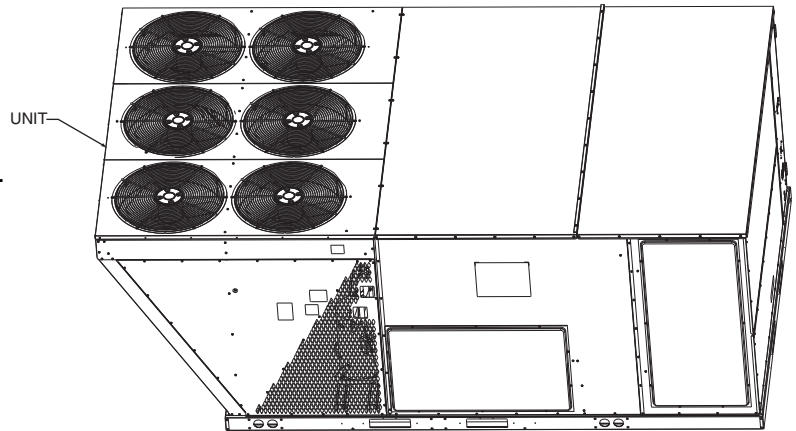

ROOFCURB ASSEMBLY

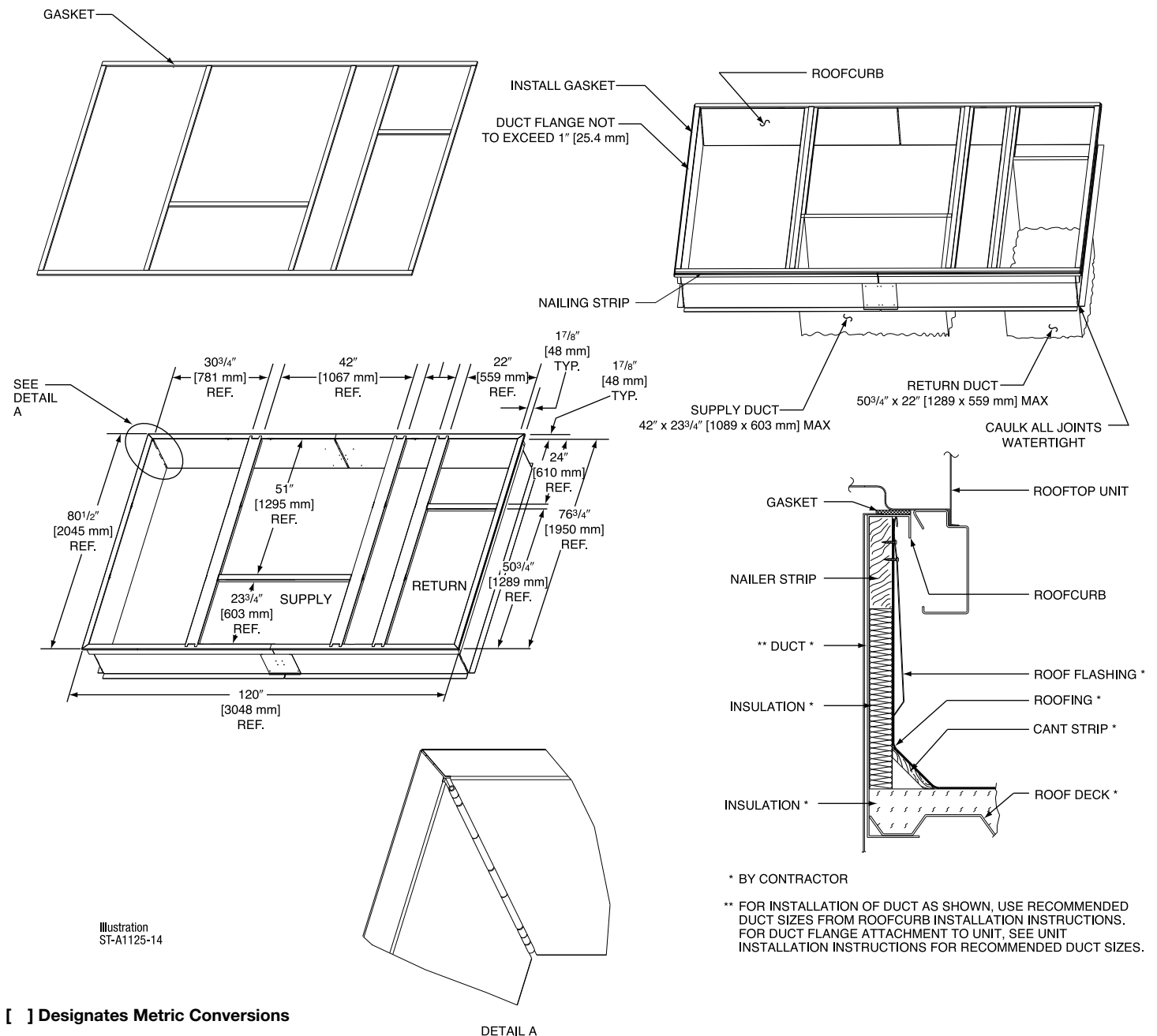

* BY CONTRACTOR
 ** FOR INSTALLATION OF DUCT AS SHOWN, USE RECOMMENDED DUCT SIZES FROM ROOFCURB INSTALLATION INSTRUCTIONS. FOR DUCT FLANGE ATTACHMENT TO UNIT, SEE UNIT INSTALLATION INSTRUCTIONS FOR RECOMMENDED DUCT SIZES.

[] Designates Metric Conversions

ROOFCURB ADAPTER

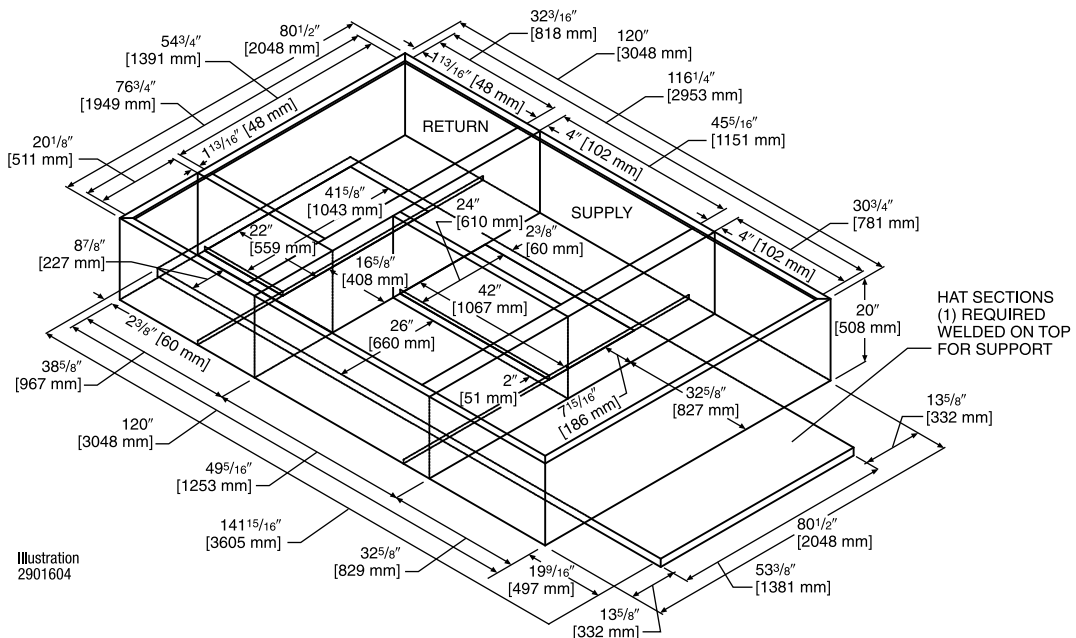
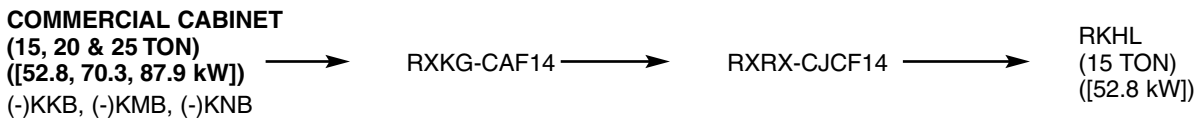
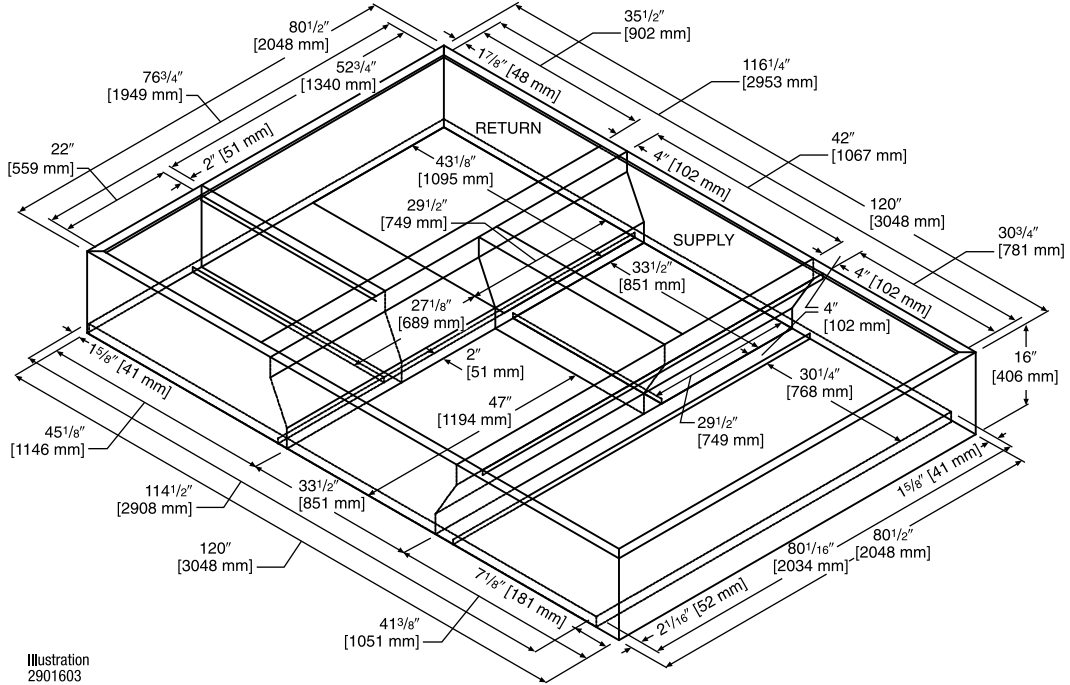
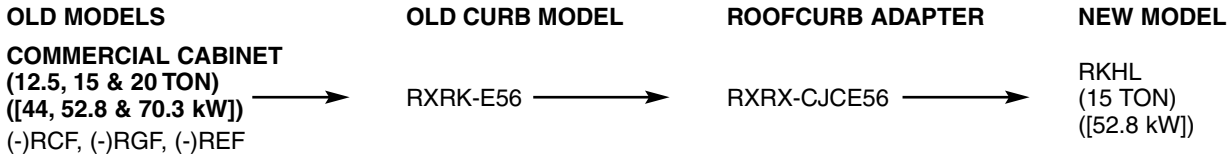

[] Designates Metric Conversions

CONCENTRIC DIFFUSER APPLICATION

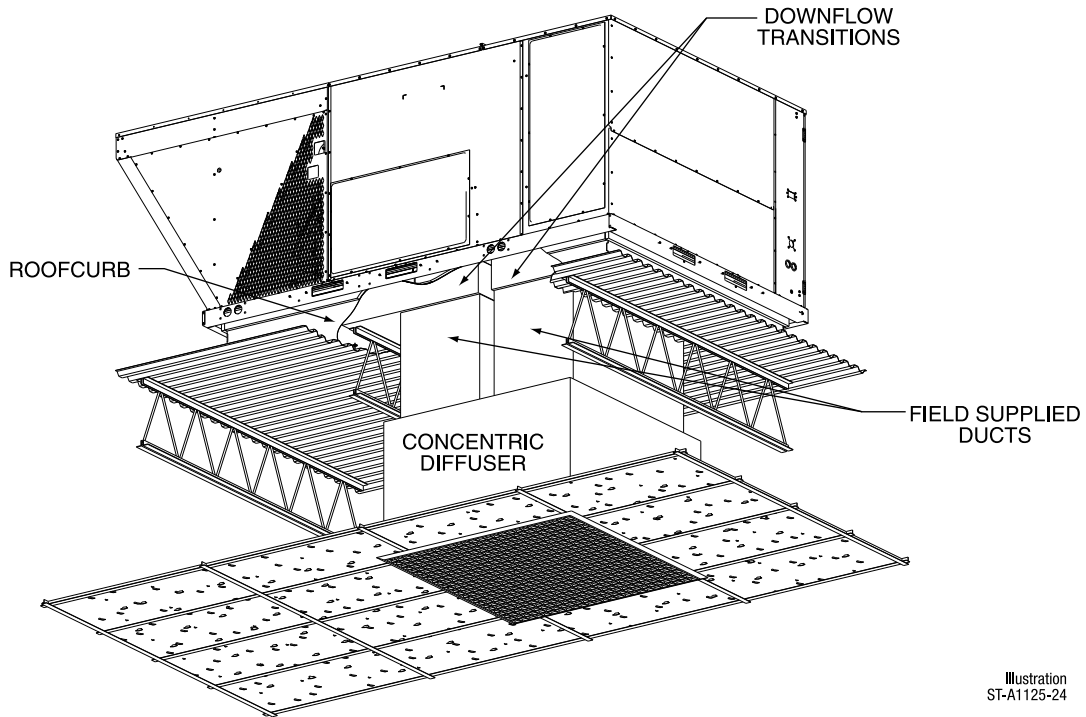

Illustration
 ST-A1125-24

DOWNFLOW TRANSITION DRAWINGS

RXMC-CJ07 (15 Ton) [52.8 kW]

- Used with RXRN-AD80 and RXRN-AD81 Concentric Diffusers.

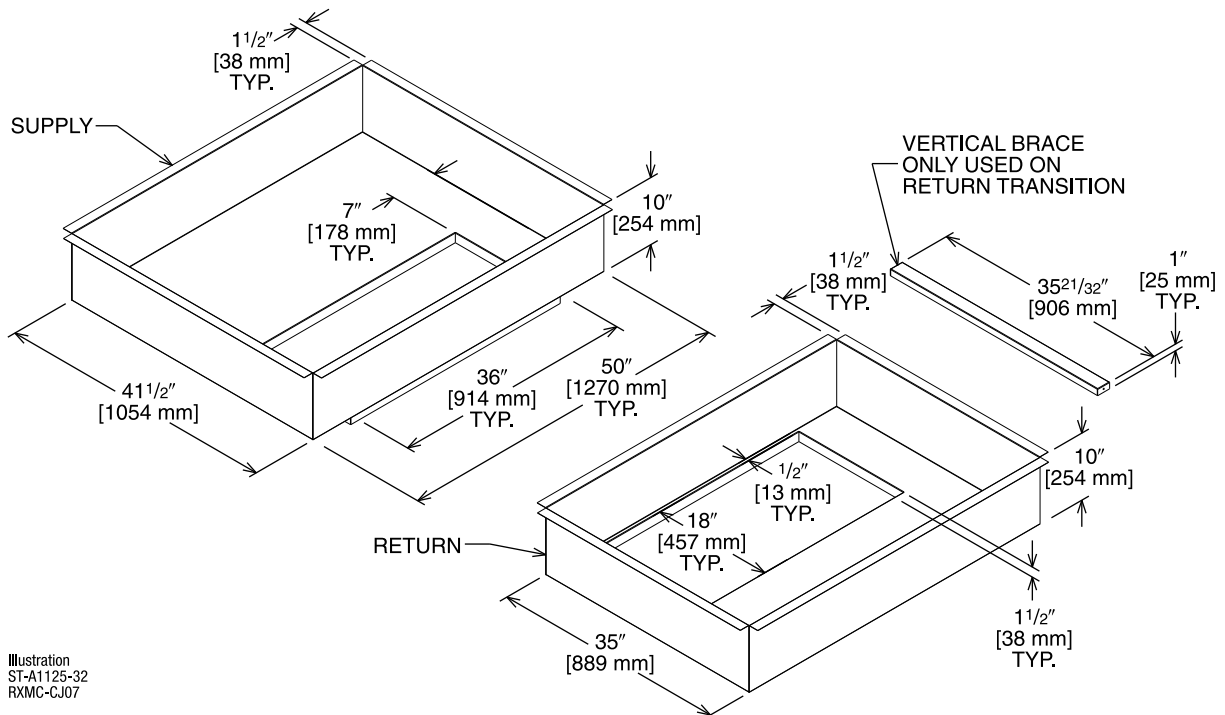
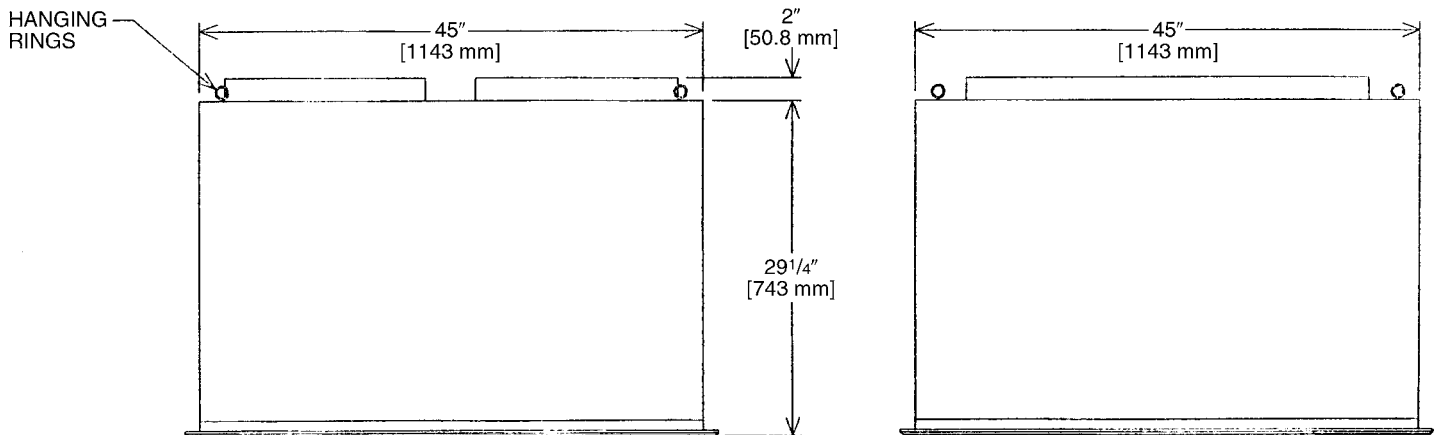
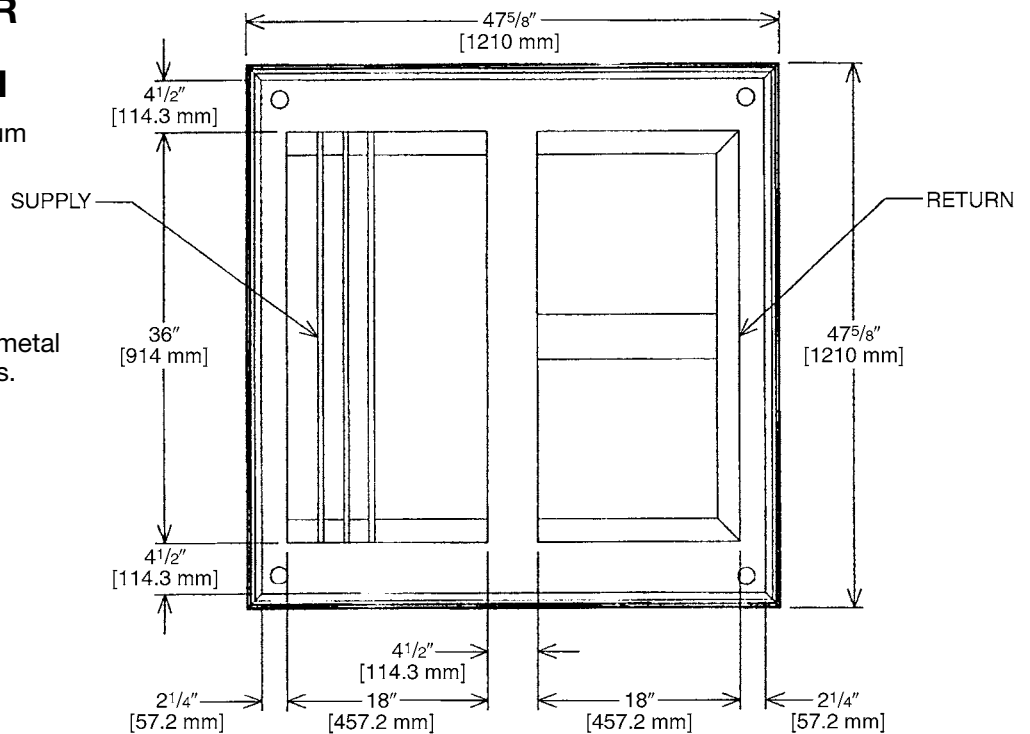

Illustration
 ST-A1125-32
 RXMC-CJ07

[] Designates Metric Conversions

CONCENTRIC DIFFUSER RXRN-AD80 SERIES 15 TON [52.8 kW] FLUSH

- All aluminum diffuser with aluminum return air eggcrate.
- Built-in anti-sweat gasket.
- Molded fiberglass supports.
- Built-in hanging supports.
- Diffuser box constructed of sheetmetal insulated with 1" [25.4 mm] 1.5 lbs. [.7 kg] duct liner.



CONCENTRIC DIFFUSER SPECIFICATIONS

PART NUMBER	CFM [L/s]	STATIC PRESSURE	THROW FEET	NECK VELOCITY	JET VELOCITY
RXRN-AD80	5600 [2643]	0.36	28-37	1000	2082
	5800 [2737]	0.39	29-38	1036	2156
	6000 [2832]	0.42	40-50	1071	2230
	6200 [2926]	0.46	42-51	1107	2308
	6400 [3020]	0.50	43-52	1143	2379
	6600 [3115]	0.54	45-56	1179	2454

[] Designates Metric Conversions

CONCENTRIC DIFFUSER RXRN-AD81 SERIES 15 TON [52.8 kW] STEP DOWN

- All aluminum diffuser with aluminum return air eggcrate.
- Built-in anti-sweat gasket.
- Molded fiberglass supports.
- Built-in hanging supports.
- Diffuser box constructed of sheetmetal insulated with 1" [25.4 mm] 1.5 lbs. [.7 kg] duct liner.
- Double deflection diffuser with the blades secured by spring steel.

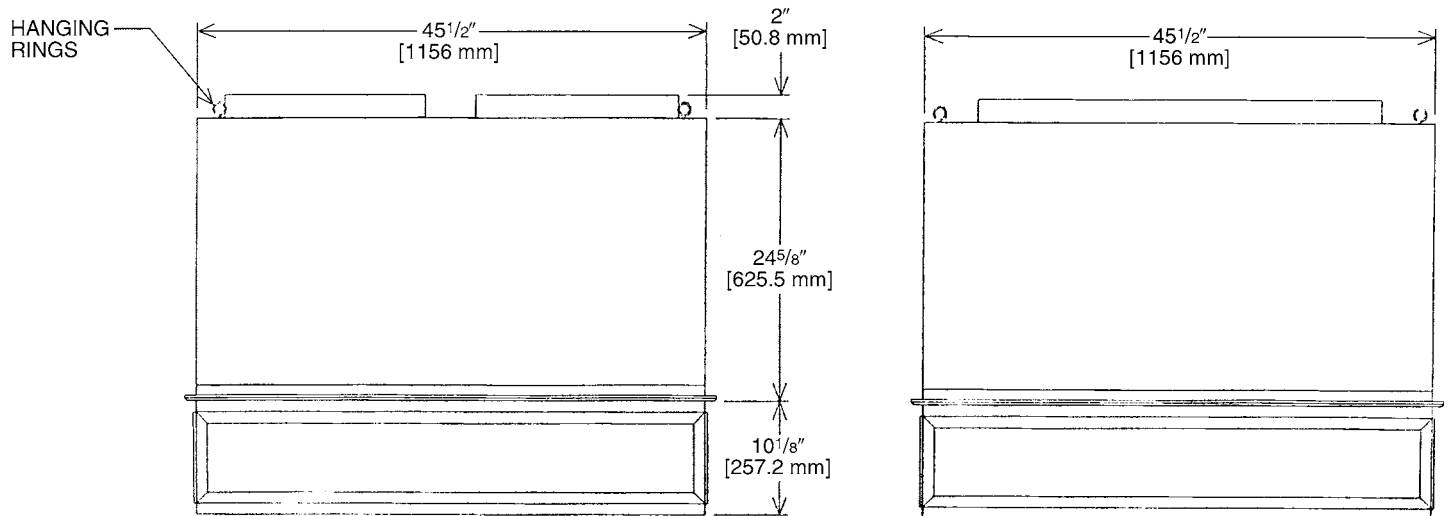
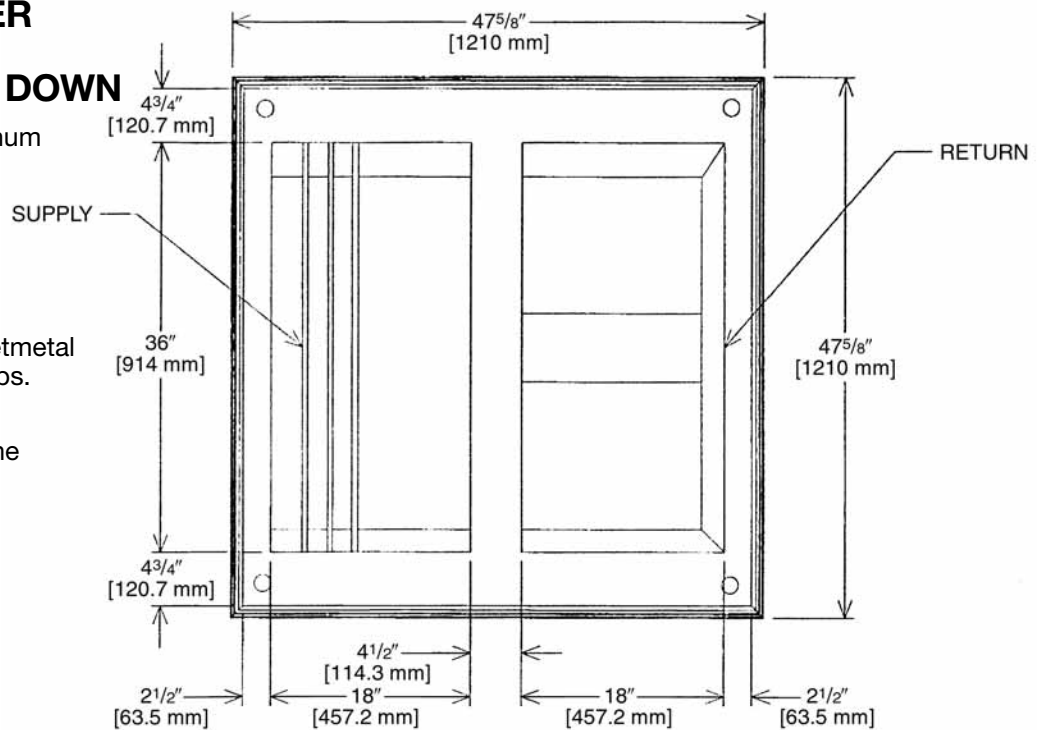

CONCENTRIC DIFFUSER SPECIFICATIONS

PART NUMBER	CFM [L/s]	STATIC PRESSURE	THROW FEET	NECK VELOCITY	JET VELOCITY
RXRN-AD81	5600 [2643]	0.36	39-49	920	920
	5800 [2737]	0.39	42-51	954	954
	6000 [2832]	0.42	44-54	1022	1022
	6200 [2926]	0.46	45-55	1056	1056
	6400 [3020]	0.50	46-55	1090	1090
	6600 [3115]	0.54	47-56	1124	1124

[] Designates Metric Conversions

FLUSH VALVE KIT

RXMV-AG

Contains two valves with union and 1-1/2" FPT connections for the H₂AC Rooftop Unit water lines

- Field Installed accessory serves as the H₂AC Rooftop Unit water shut off valves during unit servicing.
- Aids in the periodic flushing required for the refrigerant-to-water heat exchanger contained in the H₂AC Rooftop Unit unit to remove lime and scale buildup and to prevent degradation of water heating performance.
- Features 3/4" threaded hose connections for draining.



EMERGENCY ELECTRICALLY OPERATED WATER SHUTOFF VALVE

RXMV-AH

Shuts off water supply to the H₂AC Rooftop Unit unit if a leak is detected by the onboard sensor

- Field Installed accessory provided with 1-1/2" FPT connections.
- Standard Port, Bronze Ball Valve for low water pressure drop.
- 115 VAC motor connects to alarm dry contacts on eSync unit and separate power supply.
- Standard position indicator.
- Manual override standard.
- Mountable in any position.



WATER STORAGE TANK MANIFOLD KIT

RXMZ-A120A

Compact tank-hugging design provides components to connect the H₂AC rooftop unit to the water storage tank and the rest of the potable water heating system

- Field Installed accessory with 1-1/2" sweat connections to the H₂AC unit and 2" sweat connections to the hot water system.
- Reduces plumbing errors that prevent proper operation of the H₂AC unit. Components meet California law AB 1953 low-lead requirements.
- Standard Port, Bronze Ball Shutoff Valves for low water pressure drop.
- Bronze Check Valves prevent loss of H₂AC water pump prime during temporary water pressure loss and prevent water backflow when Emergency Water Shutoff valve is energized.
- Includes Di-electric Nipples and Di-electric Unions to water storage tank for building code compliance.
- Includes 3/4" hose bibs to bleed air out of the system after initial installation and to drain system for servicing.
- Includes bronze plugs for unused storage tank connections.

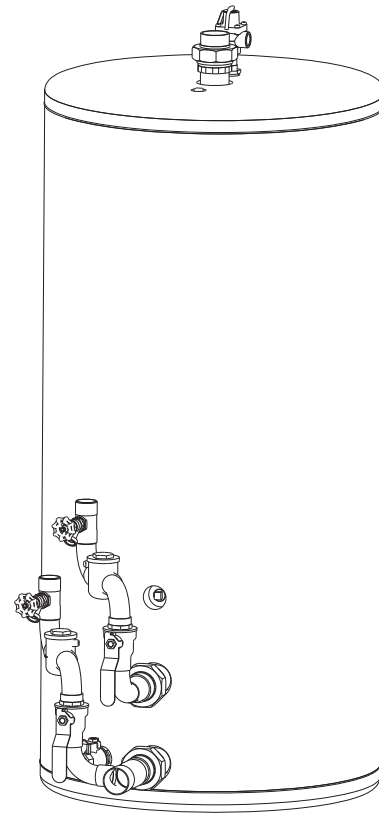

Guide Specifications RKHL-D 180

You may copy this document directly into your building specification. This specification is written to comply with the 2004 version of the “master format” as published by the Construction Specification institute. www.csinet.org.

GAS HEAT PACKAGED ROOFTOP

HVAC Guide Specifications

Size Range: 15 Nominal Tons

<u>Section</u>	<u>Description</u>
----------------	--------------------

23 06 80	Domestic Water Brazed-Plate Heat Exchangers
-----------------	--

22 35 36	A Domestic Water Brazed-Plate Heat Exchangers
-----------------	--

1. Unit shall contain a Double Wall, Vented, Brazed-Plate heat exchanger to provide preheating of domestic potable water by using refrigerant waste heat recovery from the packaged air conditioner.
2. Heat exchanger shall be mounted in the indoor air section of the packaged air conditioner.
3. Unit shall be provided with a stainless steel recirculation pump suitable for potable water.
4. Unit shall include controls to switch from air conditioning to water heating mode whenever heat recovery is possible.

23 06 80	Schedules for Decentralized HVAC Equipment
-----------------	---

23 06 80.13	Decentralized Unitary HVAC Equipment Schedule
--------------------	--

23 06 80.13.A.	Rooftop unit schedule
-----------------------	------------------------------

1. Schedule is per the project specification requirements.

23 07 16	HVAC Equipment Insulation
-----------------	----------------------------------

23 07 16.13	Decentralized, Rooftop Units:
--------------------	--------------------------------------

23 07 16.13.A.	Evaporator fan compartment:
-----------------------	------------------------------------

1. Interior cabinet surfaces shall be insulated with a minimum 3/4-in. thick, minimum 1-1/2 lb density, flexible fiberglass insulation bonded with foil face on the air side.
2. Insulation and adhesive shall meet NFPA 90A requirements for flame spread and smoke generation.
3. Insulation shall also be mechanically fastened with welded pin and retainer washer.

23 07 16.13.B.	Gas heat compartment:
-----------------------	------------------------------

1. Aluminum foil-faced fiberglass insulation shall be used.
2. Insulation and adhesive shall meet NFPA 90A requirements for flame spread and smoke generation.
3. Insulation shall also be mechanically fastened with welded pin and retainer washer.

23 09 13	Instrumentation and Control Devices for HVAC
-----------------	---

23 09 13.23	Sensors and Transmitters:
--------------------	----------------------------------

23 09 13.23.A.	Thermostats
-----------------------	--------------------

1. Thermostat must
 - a. have capability to energize 2 different stages of cooling, and 2 different stages of heating.
 - b. must include capability for occupancy scheduling.

23 09 23	Direct-digital Control system for HVAC
-----------------	---

23 09 23.13	Decentralized, Rooftop Units:
--------------------	--------------------------------------

23 09 23.13.A.	RTU-C controller
-----------------------	-------------------------

1. Shall be ASHRAE 62-2001 compliant.
2. Shall accept 18-32VAC input power.
3. Shall have an operating temperature range from -40°F (-40°C) to 158°F (70°C), 10% - 95% RH (non-condensing).
4. Controller shall accept the following inputs: space temperature, setpoint adjustment, outdoor air temperature, indoor air quality, outdoor air enthalpy, fire shutdown, return air enthalpy, fan status, remote time clock/door switch.
5. Shall accept a CO₂ sensor in the conditioned space, and be Demand Control Ventilation (DCV) ready.
6. Shall provide the following outputs: Economizer, fan, cooling stage 1, cooling stage 2, heat stage 1, heat stage 2/ exhaust/occupied.
7. Unit shall provide surge protection for the controller through a circuit breaker.
8. Shall have a field installed communication card allowing the unit to be Internet capable, and communicate at a Baud rate of 19.2K or faster
9. Shall have an LED display independently showing the status of activity on the communication bus, and processor operation.
10. Shall have either a field installed BACnet® plug-in communication card which includes an EIA-485 protocol communication port, or a field installed LonWorks™ plug-in communications card.

11. Software upgrades will be accomplished by local download. Software upgrades through chip replacements are not allowed.
 12. Shall be shock resistant in all planes to 5G peak, 11ms during operation, and 100G peak, 11ms during storage.
 13. Shall be vibration resistant in all planes to 1.5G @ 20-300 Hz.
 14. Shall support a bus length of 4000 ft max, 60 devices per 1000 ft section, and 1 RS-485 repeater per 1000 ft sections
- 23 09 23.13.B. Open protocol, direct digital controller:
1. Shall be ASHRAE 62-2001 compliant.
 2. Shall accept 18-30VAC, 50-60Hz, and consume 15VA or less power.
 3. Shall have an operating temperature range from -40°F (-40°C) to 130°F (54°C), 10% - 90% RH (non-condensing).
 4. Shall have either a field installed BACnet® plug-in communication card which includes an EIA-485 protocol communication port, or a field installed LonWorks™ plug-in communications card.
 5. The BACnet® plug in communication card shall include built-in protocol for BACNET (MS/TP and PTP modes)
 6. The LonWorks™ plug in communication card shall include the Echelon processor required for all Lon applications.
 7. Shall allow access of up to 62 network variables (SNVT). Shall be compatible with all open controllers
 8. Baud rate Controller shall be selectable through the EIA-485 protocol communication port.
 9. Shall have an LED display independently showing the status of serial communication, running, errors, power, all digital out-puts, and all analog inputs.
 10. Shall accept the following inputs: space temperature, setpoint adjustment, outdoor air temperature, indoor air quality, outdoor air enthalpy, compressor lock-out, fire shutdown, enthalpy switch, and fan status/filter status/ humidity/ remote occupancy.
 11. Shall provide the following outputs: economizer, fan, cooling stage 1, cooling stage 2, heat stage 1, heat stage 2, exhaust.
 12. Software upgrades will be accomplished by either local or remote download. No software upgrades through chip replacements are allowed.

23 09 33 Electric and Electronic Control System for HVAC

23 09 33.13 Decentralized, Rooftop Units:

23 09 13.13.A. General:

1. Shall be complete with self-contained low-voltage control circuit protected by a resettable circuit breaker.
2. Shall utilize color-coded wiring.
3. Unit shall include self-contained low-voltage control circuit protected by a fuse on the 24-V transformer side with a resettable circuit breaker.
4. Shall include a central control terminal board to conveniently and safely provide connection points for vital control functions such as: smoke detectors, phase monitor, economizer, thermostat, DDC control options, loss of charge, freeze sensor, high pressure switches.
5. The heat exchanger shall be controlled by an integrated furnace controller (IFC) microprocessor. See heat exchanger section of this specification.
6. Unit shall include a minimum of one 10-pin screw terminal connection board for connection of control wiring.

23 09 33.23.B. Safeties:

1. Compressor over-temperature, over current.
2. Loss of charge switch.
 - a. Units with 2 compressors shall have different colored wires for the circuit 1 and circuit 2 low and high pressure switches.
 - b. Loss of charge switch shall use different color wire than the high pressure switch. The purpose is to assist the installer and service technician to correctly wire and or troubleshoot the rooftop unit.
 - c. Loss of charge switch shall have a different sized connector than the high pressure switch. They shall physically prevent the cross-wiring of the safety switches between the high and low pressure side of the system.
3. High-pressure switch.
 - a. Units with 2 compressors shall have different colored wires for the circuit 1 and circuit 2 low and high pressure switches.
 - b. High pressure switch shall use different color wire than the low pressure switch. The purpose is to assist the installer and service person to correctly wire and or troubleshoot the rooftop unit.
 - c. High pressure switch shall have a different sized connector than the loss of charge switch. They shall physically prevent the cross-wiring of the safety switches between the high and low pressure side of the system.
4. Freeze protection sensor, evaporator coil.
5. Automatic reset, motor thermal overload protector.
6. Heating section shall be provided with the following minimum protections:
 - a. High-temperature limit switches.
 - b. Induced draft motor pressure switch.
 - c. Flame rollout switch.
 - d. Flame proving controls.

23 09 33 Sequence of Operations for HVAC Controls**23 09 93.13 Decentralized, Rooftop Units:**

23 09 93.13 INSERT SEQUENCE OF OPERATION

23 40 13 Panel Air Filters**23 40 13.13 Decentralized, Rooftop Units:**

23 40 13.13.A.

1. Standard file section shall consist of factory-installed, low velocity, throwaway 2-in. thick fiberglass filters of commercially available sizes.
2. Unit shall use only one filter size. Multiple sizes are not acceptable.
3. Filter face velocity shall not exceed 365 fpm at nominal airflows.
4. Filters shall be accessible through an access panel with “no-tool” removal as described in the unit cabinet section of the specification (23 81 19.13.H).

23 81 19 Self-Contained Air Conditioners**23 81 19.13 (15 Ton) Capacity Self-Contained Air Conditioners**

23 81 19.13.A. General

1. Outdoor, rooftop mounted, electrically controlled, heating and cooling unit utilizing a(n) hermetic scroll compressor(s) for cooling duty and gas combustion for heating duty.
2. Factory assembled, single-piece heating and cooling rooftop unit. Contained within the unit enclosure shall be all factory wiring, piping, controls, and special features required prior to field start-up.
3. Unit shall use environmentally safe, R410A refrigerant.
4. Unit shall be installed in accordance with the manufacturer’s instructions.
5. Unit must be selected and installed in compliance with local, state, and federal codes.

23 81 19.13.B. Quality Assurance

1. Unit meets ASHRAE 90.1-2010 minimum efficiency requirements.
2. 3-phase units are Energy Star qualified.
3. Unit shall be rated in accordance with AHRI Standards 210 and 360.
4. Unit shall be designed to conform to ASHRAE 15, 2001.
5. Unit shall be UL-tested and certified in accordance with ANSI Z21.47 Standards and UL-listed and certified under Canadian standards as a total package for safety requirements.
6. Insulation and adhesive shall meet NFPA 90A requirements for flame spread and smoke generation.
7. Unit casing shall be capable of withstanding 1000-hour salt spray exposure per ASTM B117 (scribed specimen).
8. Unit casing shall be capable of withstanding Federal Test Method Standard No. 141 (Method 6061) 5000-hour salt spray.
9. Unit shall be designed in accordance with ISO 9001:2000, and shall be manufactured in a facility registered by ISO 9001:2000.
10. Roof curb shall be designed to conform to NRCA Standards.
11. Unit shall be subjected to a completely automated run test on the assembly line. The data for each unit will be stored at the factory, and must be available upon request.
12. Unit shall be designed in accordance with UL Standard 1995, including tested to withstand rain.
13. Unit shall be constructed to prevent intrusion of snow and tested to prevent snow intrusion into the control box up to 40 mph.

23 81 19.13.C. Delivery, Storage, and Handling

1. Unit shall be stored and handled per manufacturer’s recommendations.
2. Lifted by crane requires either shipping top panel or spreader bars.
3. Unit shall only be stored or positioned in the upright position.

23 81 19.13.E. Project Conditions

1. As specified in the contract.

23 81 19.13.F. Operating Characteristics

1. Unit shall be capable of starting and running at 115°F (46°C) ambient outdoor temperature, meeting maximum load criteria of AHRI Standard 210/240 or 360 at ± 10% voltage.
2. Compressor with standard controls shall be capable of operation down to 50°F (10°C), ambient outdoor temperatures. Low ambient accessory kit is necessary if mechanically cooling at ambient temperatures to 0°F (-17.7°C).
3. Unit shall be factory configured for vertical supply & return configurations.

23 81 19.13.G. Electrical Requirements

1. Main power supply voltage, phase, and frequency must match those required by the manufacturer.

23 81 19.13.H. Unit Cabinet

1. Unit cabinet shall be constructed of galvanized steel.
2. Unit cabinet exterior paint shall be: powder coat paint.
3. Evaporator fan compartment interior cabinet insulation shall conform to AHRI Standards 210 or 360 minimum exterior sweat criteria. Interior surfaces shall be insulated with a minimum 3/4-in. thick, 1-1/2 lb density, flexible fiberglass insulation, foil faced on the air side. Aluminum foil-faced fiberglass insulation shall be used in the gas heat compartment.
4. Base of unit shall have a location for thru-the-base gas and electrical connections standard.
5. Base Rail
 - a. Unit shall have base rails on a minimum of 4 sides.
 - b. Holes shall be provided in the base rails for rigging shackles to facilitate maneuvering and overhead rigging.
 - c. Holes shall be provided in the base rail for moving the rooftop by fork truck.
 - d. Base rail shall be a minimum of 14 gauge thickness.
6. Condensate pan and connections:
 - a. Shall be a sloped condensate drain pan made of a non-corrosive material and be removable for cleaning.
 - b. Shall comply with ASHRAE Standard 62.
 - c. Shall use a 1" x 11-1/2 NPT drain connection, through the side of the drain pan. Connection shall be made per manufacturer's recommendations.
 - d. Shall be able to be easily removed.
7. Top panel:
 - a. Shall be a single piece top panel over indoor section.
8. Gas Connections:
 - a. All gas piping connecting to unit gas valve shall enter the unit cabinet at a single location on side of unit (horizontal plane).
 - b. Thru-the-base capability
 - i. Standard unit shall have a thru-the-base gas-line location using a continuous raised, flange around opening in the basepan.
 - ii. No basepan penetration, other than those authorized by the manufacturer, is permitted.
9. Electrical Connections
 - a. All unit power wiring shall enter unit cabinet a a single, factory-prepared, continuous raised flange opening in the basepan.
 - b. Thru-the-base capability
 - i. Standard unit shall have a thru-the-base electrical location(s) using a raised, continuous raised flange opening in the basepan.
 - ii. No basepan penetration, other than those authorized by the manufacturer, is permitted.
10. Component access panels (standard)
 - a. Cabinet panels shall be easily opened for servicing.
 - b. Panels covering control box, indoor fan, indoor fan motor, gas components (where applicable), and filters shall have hinges with 1/4 turn fasteners.
 - c. 1/4 turn fasteners shall be permanently attached.

23 81 19.13.I. Gas Heat

1. General
 - a. Heat exchanger shall be an induced draft design. Positive pressure heat exchanger designs shall not be allowed.
 - b. Shall incorporate a direct-spark ignition system and redundant main gas valve.
 - c. Heat exchanger design shall allow combustion process condensate to gravity drain; maintenance to drain the gas heat exchanger shall not be required.
 - d. Gas supply pressure at the inlet to the rooftop unit gas valve must match that required by the manufacturer.
2. The heat exchanger shall be controlled by an integrated furnace controller (IFC) microcompressor.
 - a. IFC board shall notify users of fault using a LED (light-emitting diode).
3. Standard Heat Exchanger construction
 - a. Heat exchanger shall be of the tubular-section type constructed of a minimum of 20-gauge steel coated with a nominal 1.2 mil aluminum-silicone alloy for corrosion resistance.
 - b. Burners shall be of the in-shot type constructed of aluminum-coated steel.
 - c. Burners shall incorporate orifices for rated heat output up to 2000 ft (610m) elevation. Additional accessory kits may be required for applications above 2000 ft (610m) elevation, depending on local gas supply conditions.
 - d. Each heat exchanger tube shall contain tubulators for increased heating effectiveness.

4. Optional Stainless Steel Heat Exchanger construction
 - a. Use energy saving, direct-spark ignition system.
 - b. Use a redundant main gas valve.
 - c. Burners shall be of the in-shot type constructed of aluminum-coated steel.
 - d. All gas piping shall enter the unit cabinet at a single location on side of unit (horizontal plane).
 - e. The optional stainless steel heat exchanger shall be of the tubular-section type, constructed of a minimum of 20-gauge type 409 stainless steel.
 - f. Type 409 stainless steel shall be used in heat exchanger tubes.
 - g. Complete stainless steel heat exchanger allows for greater application flexibility.
 5. Induced draft combustion motor and blower
 - a. Shall be a direct-drive, single inlet, forward-curved centrifugal type.
 - b. Shall be made from steel with a corrosion-resistant finish.
 - c. Shall be permanently lubricated sealed bearings.
 - d. Shall have inherent thermal overload protection.
 - e. Shall have an automatic reset feature.
- 23 81 19.13.J. Coils
1. Standard Aluminum/Copper Coils:
 - a. Standard evaporator coils shall be aluminum lanced plate fins mechanically bonded to seamless internally grooved copper tubes with all joints brazed. All aluminum MicroChannel condensing coil.
 - b. Evaporator and condenser coils shall be leak tested to 150 psig, pressure tested to 400 psig, and qualified to UL 1995 burst test at 2,200 psi.
- 23 81 19.13.K. Refrigerant Components
1. Refrigerant circuit shall include the following control, safety, and maintenance features:
 - a. TXV metering system shall prevent mal-distribution of two-phase refrigerant.
 - b. Refrigerant filter drier.
 - c. Service gauge connections on suction and discharge lines.
 - d. External pressure gauge ports access shall be located in front exterior of cabinet.
 2. Compressors
 - a. Unit shall use one fully hermetic, scroll compressor for each independent refrigeration circuit.
 - b. Compressor motors shall be cooled by refrigerant gas passing through motor windings.
 - c. Compressors shall be internally protected from high discharge temperature conditions.
 - d. Compressors shall be protected from an over-temperature and over-amperage conditions by an internal, motor overload device.
 - e. Compressor shall be factory mounted on rubber grommets.
 - f. Compressor motors shall have internal line break thermal and current overload protection.
 - g. Crankcase heaters shall not be required for normal operating range.
- 23 81 19.13.L. Filter Section
1. Filters access is specified in the unit cabinet section of this specification.
 2. Filters shall be held in place by filter tray, facilitating easy removal and installation.
 3. Shall consist of factory-installed, low velocity, throw-away 2-in. thick fiberglass filters.
 4. Filter face velocity shall not exceed 320 fpm at nominal airflows.
 5. Filters shall be standard, commercially available sizes.
 6. Only one size filter per unit is allowed.
- 23 81 19.13.M. Evaporator Fan and Motor
1. Evaporator fan motor:
 - a. Shall have permanently lubricated bearings
 - b. Shall have inherent automatic-reset thermal overload protection.
 - c. Shall have a maximum continuous bhp rating for continuous duty operation; no safety factors above that rating shall be required.
 2. Belt-driven Evaporator Fan:
 - a. Belt drive shall include an adjustable-pitch motor pulley.
 - b. Shall use sealed, permanently lubricated ball-bearing type.
 - c. Blower fan shall be double-inlet type with forward-curved blades.
 - d. Shall be constructed from steel with a corrosion resistant finish and dynamically balanced.

23 81 19.13.N. Condenser Fans and Motors

1. Condenser fan motors:
 - a. Shall be a totally enclosed motor.
 - b. Shall use permanently lubricated bearings.
 - c. Shall have inherent thermal overload protection with an automatic reset feature.
 - d. Shall use a shaft-down design. Shaft-up designs including those with “rain-slinger devices” shall not be allowed.
2. Condenser Fans shall:
 - a. Shall be a direct-driven propeller type fan
 - b. Shall have aluminum blades riveted to corrosion-resistant steel spiders and shall be dynamically balanced.

23 81 19.13.O. Special Features

1. Integrated Economizers:
 - a. Integrated, gear-driven parallel modulating blade design type capable of simultaneous economizer and compressor operation.
 - b. Independent modules for vertical or horizontal return configurations shall be available. Vertical return modules shall be available as a factory installed option.
 - c. Damper blades shall be galvanized steel with metal gears. Plastic or composite blades on intake or return shall not be acceptable.
 - d. Shall include all hardware and controls to provide free cooling with outdoor air when temperature and/or humidity are below setpoints.
 - e. Shall be equipped with gear driven dampers for both the outdoor ventilation air and the return air for positive air stream control.
 - f. Shall be capable of introducing up to 100% outdoor air.
 - g. Shall be equipped with a barometric relief damper capable of relieving up to 100% return air.
 - h. Shall be designed to close damper(s) during loss-of-power situations with spring return built into motor.
 - i. Enthalpy sensor shall be provided as standard. Outdoor air sensor set point shall be adjustable and shall range from 40 to 100°F / 4 to 38°C. Additional sensor options shall be available as accessories.
 - j. The economizer controller shall also provide control of an accessory power exhaust unit function. Factory set at 70%, with a range of 0% to 100%.
 - k. The economizer shall maintain minimum airflow into the building during occupied period and provide design ventilation rate for full occupancy. A remote potentiometer may be used to override the damper set point.
 - l. Dampers shall be completely closed when the unit is in the unoccupied mode.
 - m. Economizer controller shall accept a 2-10Vdc CO₂ sensor input for IAQ/DCV control. In this mode, dampers shall modulate the outdoor-air damper to provide ventilation based on the sensor input.
 - n. Compressor lockout sensor on the unit controller is factory set at 35°F and is adjustable from 0°F (-18°C) to 50°F (10°C) and resets the cooling lockout at 5°F (+2.7°C) above the set point.
 - o. Actuator shall be direct coupled to economizer gear. No linkage arms or control rods shall be acceptable.
 - p. Economizer controller shall provide indications when in free cooling mode, in the DCV mode, or the exhaust fan contact is closed.
 - q. Economizer wire harness will have provision for smoke detector.
2. Manual damper
 - a. Manual damper package shall consist of damper, air inlet screen, and rain hood which can be preset to admit up to 50% outdoor air for year round ventilation.
3. Liquid Propane (LP) Conversion Kit
 - a. Package shall contain all the necessary hardware and instructions to convert a standard natural gas unit for use with liquefied propane, up to 2000 ft (610m) elevation.
4. Flue Shield
 - a. Flue shield shall provide protection from the hot sides of the gas flue hood.
5. Condenser Coil Hail Guard Assembly
 - a. Shall protect against damage from hail.
 - b. Shall be louvered style.
6. Unit-Mounted, Non-Fused Disconnect Switch:
 - a. Switch shall be factory-installed, internally mounted.
 - b. National Electric Code (NEC) and UL approved non-fused switch shall provide unit power shutoff.
 - c. Shall be accessible from outside the unit.
 - d. Shall provide local shutdown and lockout capability.

7. Convenience Outlet:
 - a. Non-Powered convenience outlet.
 - b. Outlet shall be powered from a separate 115-120v power source.
 - c. A transformer shall not be included.
 - d. Outlet shall be field-installed and internally mounted with easily accessible 115-v female receptacle.
 - e. Outlet shall include 15 amp GFI receptacle with independent fuse protection.
 - f. Outlet shall be accessible from outside the unit.
8. Flue Discharge Deflector:
 - a. Flue discharge deflector shall direct unit exhaust vertically instead of horizontally.
 - b. Deflector shall be defined as a "natural draft" device by the National Fuel and Gas (NFG) code.
9. Propeller Power Exhaust:
 - a. Power exhaust shall be used in conjunction with an integrated economizer.
 - b. Independent modules for vertical or horizontal return configurations shall be available.
 - c. Horizontal power exhaust shall be mounted in return ductwork.
 - d. Power exhaust shall be controlled by economizer controller operation. Exhaust fans shall be energized when dampers open past the 0-100% adjustable setpoint on the economizer control.
10. Roof Curbs (Vertical):
 - a. Formed galvanized steel with wood nailer strip and shall be capable of supporting entire unit weight.
 - b. Permits installation and securing of ductwork to curb prior to mounting unit on the curb.
11. Universal Gas Conversion Kit:
 - a. Package shall contain all the necessary hardware and instructions to convert a standard natural gas unit to operate from 2000-7000 ft (610 to 2134m) elevation with natural gas or from 0-7000 ft (90-2134m) elevation with liquefied propane.
12. Return Air Enthalpy Sensor:
 - a. The return air enthalpy sensor shall be used in conjunction with an outdoor air enthalpy sensor to provide differential enthalpy control.
13. Indoor Air Quality (CO₂) Sensor:
 - a. Shall be able to provide demand ventilation indoor air quality (IAQ) control.
 - b. The IAQ sensor shall be available in duct mount, or wall mount with LED display. The set point shall have adjustment capability.
14. Smoke detectors:
 - a. Shall be a Four-Wire Controller and Detector.
 - b. Shall be environmental compensated with differential sensing for reliable, stable, and drift-free sensitivity.
 - c. Shall use magnet-activated test/reset sensor switches.
 - d. Shall have tool-less connection terminal access.
 - e. Shall have a recessed momentary switch for testing and resetting the detector.
 - f. Controller shall include:
 - i. One set of normally open alarm initiation contacts for connection to an initiating device circuit on a fire alarm control panel
 - ii. Two Form-C auxiliary alarm relays for interface with rooftop unit or other equipment
 - iii. One Form-C supervision (trouble) relay to control the operation of the Trouble LED on a remote test/reset station
 - iv. Capable of direct connection to two individual detector modules.
 - v. Can be wired to up to 14 other duct smoke detectors for multiple fan shutdown applications.
15. Barometric relief
 - a. Shall include damper, seals, hard-ware, and hoods to relieve excess building pressure.
 - b. Damper shall gravity-close upon shutdown.

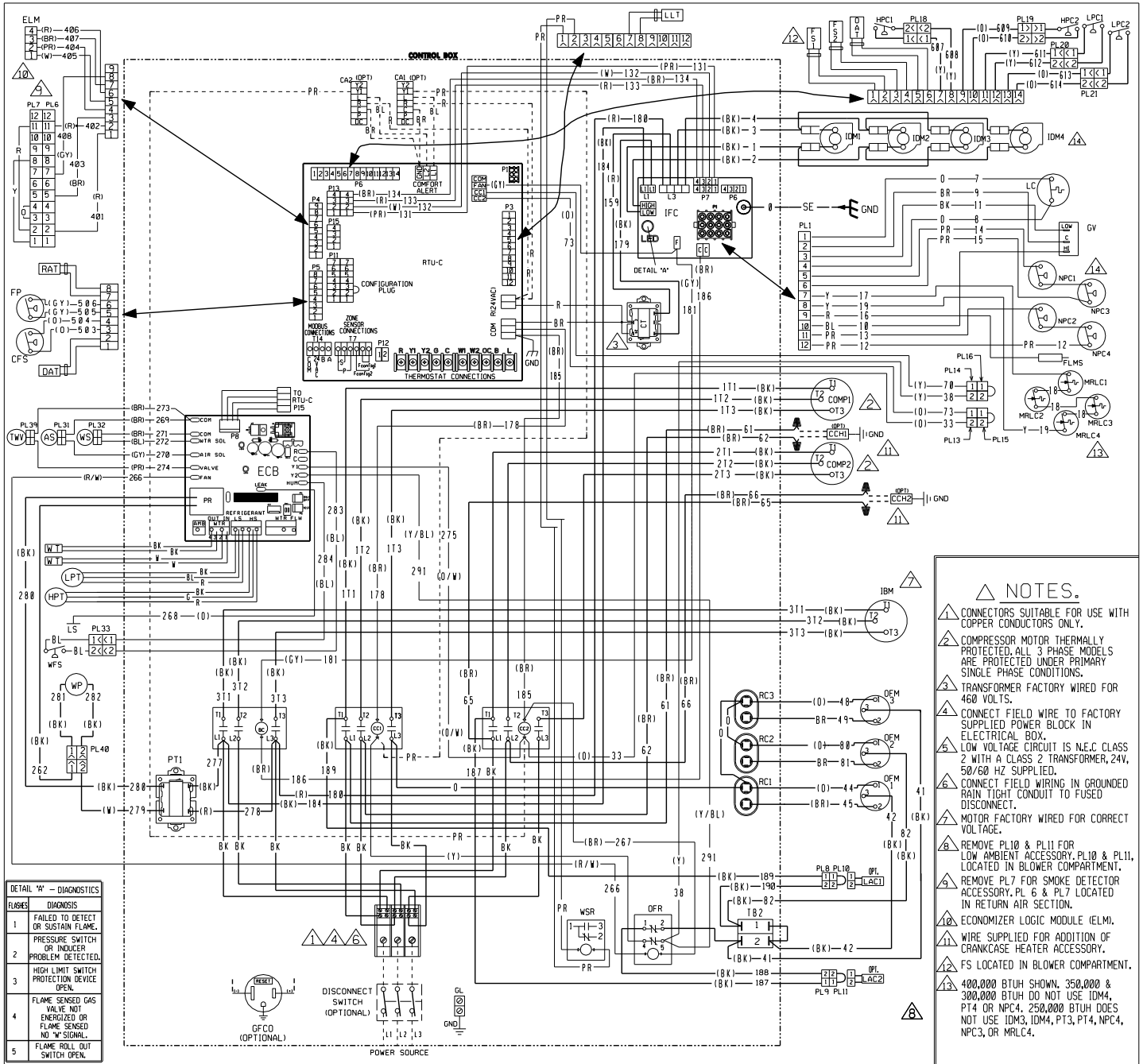

- NOTES.**
- 1. CONNECTORS SUITABLE FOR USE WITH COPPER CONDUCTORS ONLY.
 - 2. COMPRESSOR MOTOR THERMALLY PROTECTED. ALL 3 PHASE MODELS ARE PROTECTED UNDER PRIMARY SINGLE PHASE CONDITIONS.
 - 3. TRANSFORMER FACTORY WIRED FOR 460 VOLTS.
 - 4. CONNECT FIELD WIRE TO FACTORY SUPPLIED POWER BLOCK IN ELECTRICAL BOX.
 - 5. LOW VOLTAGE CIRCUIT IS N.E.C. CLASS 2 WITH A CLASS 2 TRANSFORMER, 24V, 50/60 HZ SUPPLIED.
 - 6. CONNECT FIELD WIRING IN GROUNDED RAIN TIGHT CONDUIT TO FUSED DISCONNECT.
 - 7. MOTOR FACTORY WIRED FOR CORRECT VOLTAGE.
 - 8. REMOVE PL10 & PL11 FOR LOW AMBIENT ACCESSORY. PL10 & PL11, LOCATED IN BLOWER COMPARTMENT.
 - 9. REMOVE PL7 FOR SMOKE DETECTOR ACCESSORY. PL 6 & PL7 LOCATED IN RETURN AIR SECTION.
 - 10. ECONOMIZER LOGIC MODULE (ELM).
 - 11. WIRE SUPPLIED FOR ADDITION OF CRANKCASE HEATER ACCESSORY.
 - 12. FS LOCATED IN BLOWER COMPARTMENT.
 - 13. 400,000 BTUH SHOWN. 350,000 & 300,000 BTUH DO NOT USE IDM4, PT4 OR NPC4. 250,000 BTUH DOES NOT USE IDM3, IDM4, PT3, PT4, NPC4, NPC3, OR MRLC4.

DETAIL 'W' - DIAGNOSTICS

FLASH	DIAGNOSIS
1	FAILED TO DETECT OR SUSTAIN FLAME.
2	PRESSURE SWITCH OR INDUCER PROBLEM DETECTED.
3	HIGH LIMIT SWITCH PROTECTION DEVICE OPEN.
4	FLAME SENSED GAS VALVE NOT ENERGIZED OR FLAME SENSED NO "W" SIGNAL.
5	FLAME ROLL OUT SWITCH OPEN.

COMPONENT CODE

AS AIR SOLENOID	HPT HIGH PRESSURE TRANSDUCER	RC RUN CAPACITOR
BC BLOWER CONTACTOR	IBM INDOOR BLOWER MOTOR	RTU-C ROOFTOP UNIT CONTROL
CA COMFORT ALERT MODULE	IDM INDUCED DRAFT MOTOR	SE SPARK ELECTRODE
CC COMPRESSOR CONTACTOR	IFC INTEGRATED FURNACE CONTROL	TB TERMINAL BLOCK
CCH CRANKCASE HEATER	LAC LOW AMBIENT COOLING CONTROL	TWV THREE-WAY VALVE
CFS CLOGGED FILTER SWITCH	LC LIMIT CONTROL	WFS WATER FLOW SWITCH
COMP COMPRESSOR	LPC LIQUID LINE TEMPERATURE	WP WATER PUMP
CT CONTROL TRANSFORMER	LPT LOW PRESSURE CONTROL	WS WATER SOLENOID
DAT DISCHARGE AIR SENSOR	LPT LOW PRESSURE TRANSDUCER	WSR WATER SHUTOFF RELAY
DISC DISCONNECT SWITCH	LS LEAK SENSOR	WT WATER TEMPERATURE SENSOR
ECB ESYNC CONTROL BOARD	MRLC MANUAL RESET LIMIT CONTROL	WN WIRE NUT
FLMS FLAME SENSOR	NPC NEGATIVE PRESSURE CONTROL	
FP FAN PROVING	OAT OUTSIDE AIR SENSOR	
FS FREEZE SENSOR	OFM OUTDOOR FAN MOTOR	
GFCO GROUND FAULT CONVENIENCE OUTLET	OFM OUTDOOR FAN RELAY	
GL GROUND LUG	PL PLUG	
GND GROUND	PR PUMP RELAY	
GV GAS VALVE	PT POWER TRANSFORMER	
HPC HIGH PRESSURE CONTROL	RAT RETURN AIR SENSOR	

WIRING INFORMATION

LINE VOLTAGE
 -FACTORY STANDARD _____
 -FACTORY OPTION - - - - -
 -FIELD INSTALLED - - - - -

LOW VOLTAGE
 -FACTORY STANDARD _____
 -FACTORY OPTION - - - - -
 -FIELD INSTALLED - - - - -

REPLACEMENT WIRE
 -MUST BE THE SAME SIZE AND TYPE OF INSULATION AS ORIGINAL (105° C MIN.)

WARNING
 -CABINET MUST BE PERMANENTLY GROUNDED AND CONFORM TO I.E.C., N.E.C., C.E.C., AND LOCAL CODES AS APPLICABLE.

WIRE COLOR CODE

BK BLACK	O ORANGE
BR BROWN	PR PURPLE
BL BLUE	R RED
G GREEN	W WHITE
GY GRAY	Y YELLOW

WIRING DIAGRAM
RKHL-D180
 460V 3 PH, 60 HZ.
 ROOFTOP W/RTU-C

DR. BY MGR	APP. BY	DATE 1-3-13	DWG. NO. 90-104652-02	REV 00
---------------	---------	----------------	--------------------------	-----------

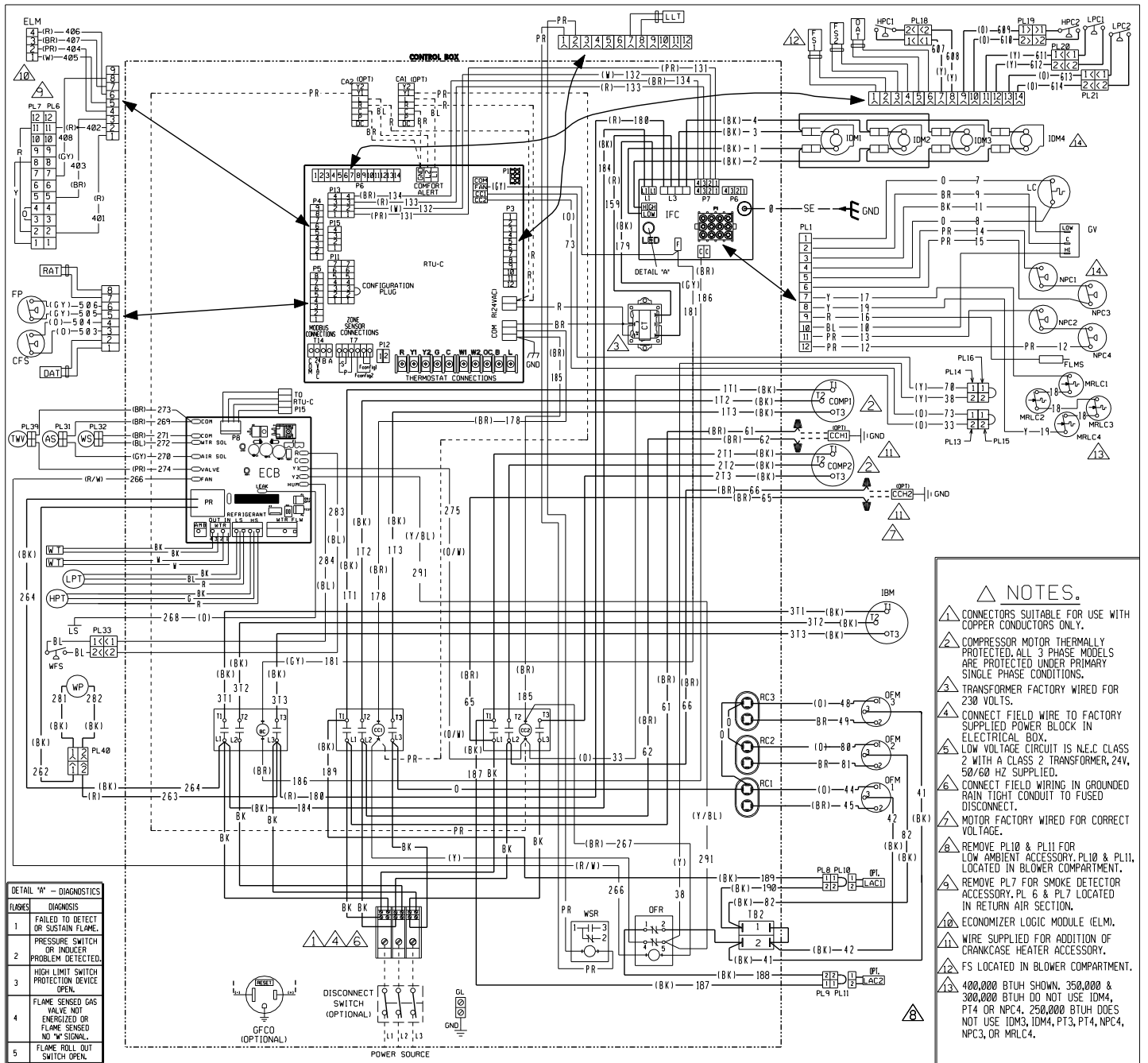

- NOTES.**
- 1 CONNECTORS SUITABLE FOR USE WITH COPPER CONDUCTORS ONLY.
 - 2 COMPRESSOR MOTOR THERMALLY PROTECTED. ALL 3 PHASE MODELS ARE PROTECTED UNDER PRIMARY SINGLE PHASE CONDITIONS.
 - 3 TRANSFORMER FACTORY WIRED FOR 230 VOLTS.
 - 4 CONNECT FIELD WIRE TO FACTORY SUPPLIED POWER BLOCK IN ELECTRICAL BOX.
 - 5 LOW VOLTAGE CIRCUIT IS N.E.C. CLASS 2 WITH A CLASS 2 TRANSFORMER, 24V, 50/60 HZ SUPPLIED.
 - 6 CONNECT FIELD WIRING IN GROUNDED RAIN TIGHT CONDUIT TO FUSED DISCONNECT.
 - 7 MOTOR FACTORY WIRED FOR CORRECT VOLTAGE.
 - 8 REMOVE PL10 & PL11 FOR LOW AMBIENT ACCESSORY. PL10 & PL11 LOCATED IN BLOWER COMPARTMENT.
 - 9 REMOVE PL7 FOR SMOKE DETECTOR ACCESSORY. PL 6 & PL7 LOCATED IN RETURN AIR SECTION.
 - 10 ECONOMIZER LOGIC MODULE (ELM).
 - 11 WIRE SUPPLIED FOR ADDITION OF CRANKCASE HEATER ACCESSORY.
 - 12 FS LOCATED IN BLOWER COMPARTMENT.
 - 13 400,000 BTUH SHOWN. 350,000 & 300,000 BTUH DO NOT USE IDM4, PT4 OR NPC4. 250,000 BTUH DOES NOT USE IDM3, IDM4, PT3, PT4, NPC4, NPC3, OR MRLC4.

DETAIL "M" - DIAGNOSTICS

TURNOFF	DIAGNOSIS
1	FAILED TO DETECT OR SUSTAIN FLAME.
2	PRESSURE SWITCH OR INDUCER PROBLEM DETECTED.
3	HIGH LIMIT SWITCH PROTECTION DEVICE OPEN.
4	FLAME SENSED GAS VALVE NOT ENERGIZED OR FLAME SENSED NO "W" SIGNAL.
5	FLAME ROLL OUT SWITCH OPEN.

COMPONENT CODE		WIRING INFORMATION		WIRE COLOR CODE	
AS	AIR SOLENOID	LINE VOLTAGE	-FACTORY STANDARD	BK	BLACK
BC	BLOWER CONTACTOR	-FACTORY OPTION	-----	BR	BROWN
CA	COMFORT ALERT MODULE	-FIELD INSTALLED	-----	BL	BLUE
CC	COMPRESSOR CONTACTOR	LOW VOLTAGE	-FACTORY STANDARD	G	GREEN
CCH	CRANKCASE HEATER	-FACTORY OPTION	-----	GY	GRAY
CFS	CLOGGED FILTER SWITCH	-FIELD INSTALLED	-----		
COMP	COMPRESSOR	REPLACEMENT WIRE	-MUST BE THE SAME SIZE AND TYPE OF INSULATION AS ORIGINAL (105° C MIN.)		
CT	CONTROL TRANSFORMER	WARNING	-CABINET MUST BE PERMANENTLY GROUNDED AND CONFORM TO I.E.C., N.E.C., C.E.C., AND LOCAL CODES AS APPLICABLE.		
CD	DISCHARGE AIR SENSOR				
DISC	DISCONNECT SWITCH				
ECB	ESYNC CONTROL BOARD				
FLMS	FLAME SENSOR				
FP	FAN PROVING				
FS	FREZE SENSOR				
GFCD	GROUND FAULT CONVENIENCE OUTLET				
GL	GROUND LUG				
GND	GROUND				
GV	GAS VALVE				
HPC	HIGH PRESSURE CONTROL				
HPT	HIGH PRESSURE TRANSDUCER				
IBM	INDOOR BLOWER MOTOR BELT DRIVE				
ICM	INDUCED DRAFT MOTOR				
IDM	INDUCED DRAFT MOTOR				
IFC	INTEGRATED FURNACE CONTROL				
LAC	LOW AMBIENT COOLING CONTROL				
LC	LIMIT CONTROL				
LLT	LIQUID LINE TEMPERATURE LEAK SENSOR				
LPT	LOW PRESSURE TRANSDUCER				
LPS	LOW PRESSURE SWITCH				
MLRC	MANUAL RESET LIMIT CONTROL				
NPC	NEGATIVE PRESSURE CONTROL				
OAT	OUTSIDE AIR SENSOR				
OAFM	OUTDOOR FAN MOTOR				
OFR	OUTDOOR FAN RELAY				
PL	PLUG				
PLR	PUMP RELAY				
PT	POWER TRANSFORMER				
RAT	RETURN AIR SENSOR				
RC	RUN CAPACITOR				
RTU-C	ROOFTOP UNIT CONTROL				
SE	SPARK ELECTRODE				
TB	TERMINAL BLOCK				
TW	THREE-WAY VALVE				
WFS	WATER FLOW SWITCH				
WP	WATER PUMP				
WS	WATER SOLENOID				
WSR	WATER SHUTOFF RELAY				
WT	WATER TEMPERATURE SENSOR				
▲	WIRE NUT				

DR. BY	APP. BY	DATE	DWG. NO.	REV
MGR		1-3-13	90-104652-01	00

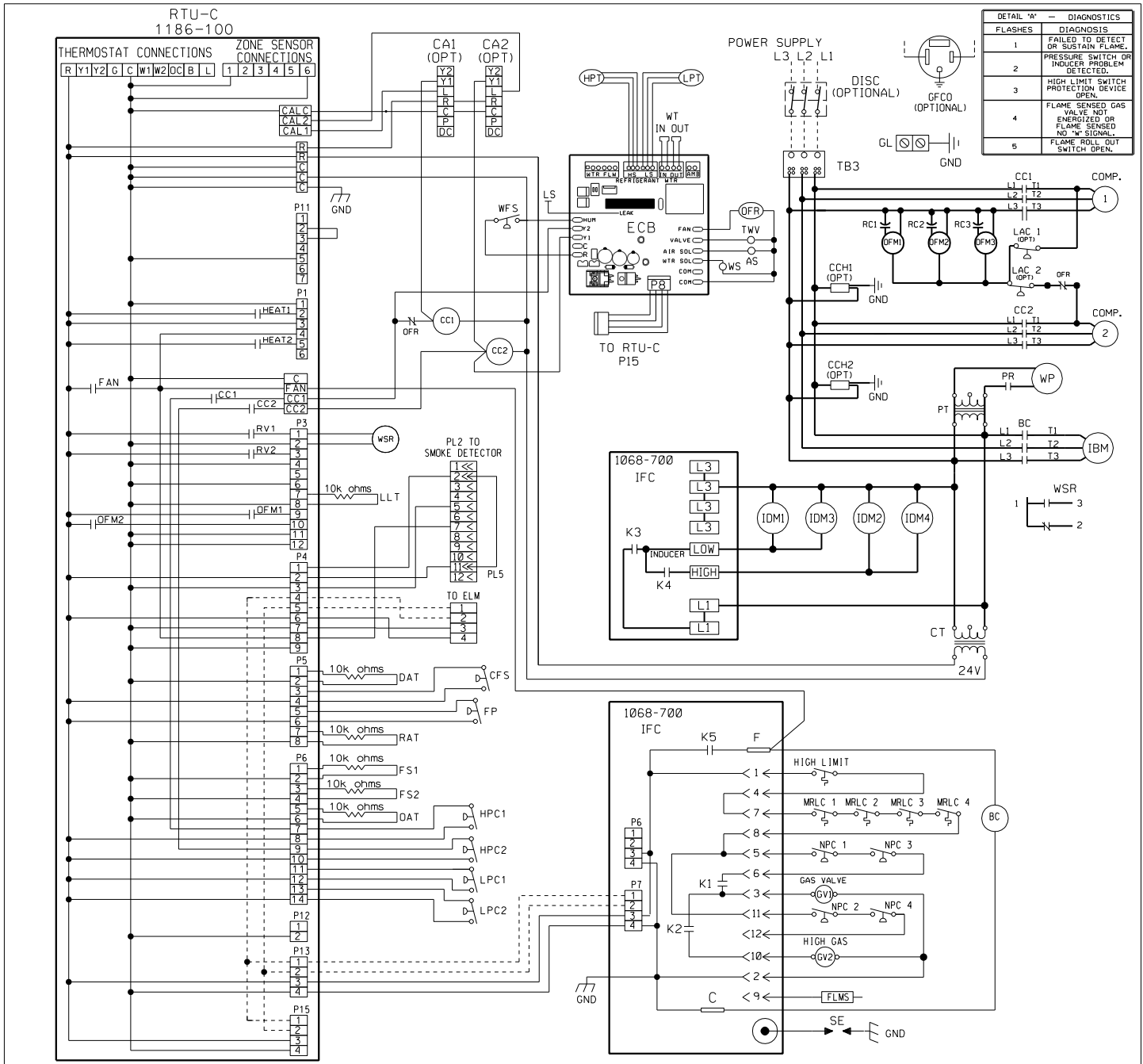

FLASHES	DIAGNOSIS
1	FAILED TO DETECT OR SUSTAIN FLAME.
2	PRESSURE SWITCH OR INDUCER PROBLEM DETECTED.
3	HIGH LIMIT SWITCH PROTECTION DEVICE OPEN.
4	FLAME SENSED GAS VALVE NOT ENERGIZED OR FLAME SENSED NO "W" SIGNAL.
5	FLAME ROLL OUT SWITCH OPEN.

COMPONENT CODE	
AS	AIR SOLENOID
BC	BLOWER CONTACTOR
CA	COMFORT ALERT MODULE
CC	COMPRESSOR CONTACTOR
CCH	CRANKCASE HEATER
CFS	CLOGGED FILTER SWITCH
COMP	COMPRESSOR
CT	CONTROL TRANSFORMER
DAT	DISCHARGE AIR SENSOR
DISC	DISCONNECT SWITCH
FLMS	FLAME SENSOR
ECB	eSYNC CONTROL BOARD
ELM	EVAPORATOR LOGIC MODULE
FP	FAN PROVING
FS	FREEZE SENSOR
GFCO	GROUND FAULT CONVENIENCE OUTLET
GL	GROUND LUG
GND	GROUND
GV	GAS VALVE
HPC	HIGH PRESSURE CONTROL
HPT	HIGH PRESSURE TRANSDUCER
IBM	INDOOR BLOWER MOTOR
CA	COMFORT ALERT MODULE
CC	COMPRESSOR CONTACTOR
CCH	CRANKCASE HEATER
CFS	CLOGGED FILTER SWITCH
COMP	COMPRESSOR
CT	CONTROL TRANSFORMER
DAT	DISCHARGE AIR SENSOR
DISC	DISCONNECT SWITCH
FLMS	FLAME SENSOR
ECB	eSYNC CONTROL BOARD
ELM	EVAPORATOR LOGIC MODULE
FP	FAN PROVING
FS	FREEZE SENSOR
GFCO	GROUND FAULT CONVENIENCE OUTLET
GL	GROUND LUG
GND	GROUND
GV	GAS VALVE
HPC	HIGH PRESSURE CONTROL
HPT	HIGH PRESSURE TRANSDUCER
IBM	INDOOR BLOWER MOTOR
IBM	INDOOR BLOWER MOTOR
IDM	INDUCED DRAFT MOTOR
IFC	INTEGRATED FURNACE CONTROL
LAC	LOW AMBIENT COOLING CONTROL
LC	LIMIT CONTROL
LLT	LIQUID LINE TEMPERATURE
LPC	LOW PRESSURE CONTROL
LPT	LOW PRESSURE TRANSDUCER
LS	LEAK SENSOR
MRLC	MANUAL RESET LIMIT CONTROL
NPC	NEGATIVE PRESSURE CONTROL
NPC	NEGATIVE PRESSURE CONTROL
DAT	DISCHARGE AIR SENSOR
OPM	OUTDOOR FAN MOTOR
OPR	OUTDOOR FAN RELAY
PL	PLUG
PR	PUMP RELAY
PT	POWER TRANSFORMER
RAT	RETURN AIR SENSOR
RC	RUN CAPACITOR
RTU-C	ROOFTOP UNIT CONTROL
SE	SPARK ELECTRODE
TB	TERMINAL BLOCK
TWV	THREE-WAY VALVE
WFS	WATER FLOW SWITCH
WP	WATER PUMP
WS	WATER SOLENOID
WSR	WATER SHUTOFF RELAY
WT	WATER TEMPERATURE SENSOR
WN	WIRE NUT

WIRING INFORMATION	
LINE VOLTAGE	
-FACTORY STANDARD	_____
-FACTORY OPTION	-----
-FIELD INSTALLED	-----
LOW VOLTAGE	
-FACTORY STANDARD	_____
-FACTORY OPTION	-----
-FIELD INSTALLED	-----
REPLACEMENT WIRE	
-MUST BE THE SAME SIZE AND TYPE OF INSULATION AS ORIGINAL (105° C MIN.)	
WARNING	
-CABINET MUST BE PERMANENTLY GROUNDED AND CONFORM TO I.E.C., N.E.C., C.E.C., AND LOCAL CODES AS APPLICABLE.	

WIRE COLOR CODE			
BK	BLACK	O	ORANGE
BR	BROWN	PR	PURPLE
BL	BLUE	R	RED
G	GREEN	W	WHITE
GY	GRAY	Y	YELLOW

WIRING SCHEMATIC			
RKHL-D180			
460V 3 PH, 60 HZ.			
ROOFTOP W/RTU-C			
DR. BY	APP. BY	DATE	DWG. NO.
MGR		1-4-13	90-104655-02
			REV 00

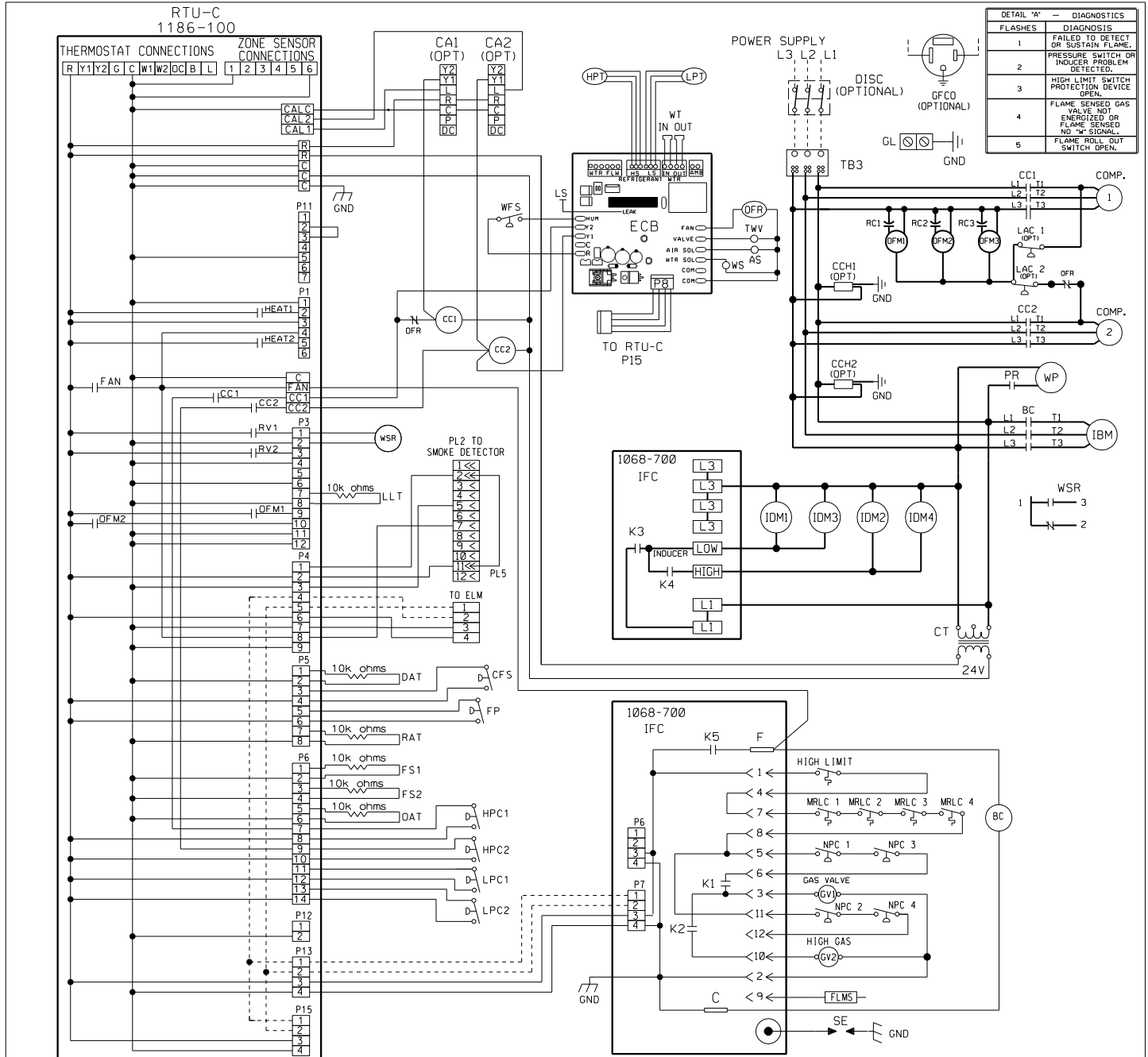

DETAIL 'A' - DIAGNOSTICS	
FLASHES	DIAGNOSTICS
1	FAILED TO DETECT OR SUSTAIN FLAME.
2	PRESSURE SWITCH OR INDUCER PROBLEM DETECTED.
3	HIGH LIMIT SWITCH PROTECTION DEVICE OPEN.
4	FLAME SENSED GAS VALVE NOT ENERGIZED OR FLAME SENSED NO "W" SIGNAL.
5	FLAME ROLL OUT SWITCH OPEN.

COMPONENT CODE	
AS	AIR SOLENOID
BC	BLOWER CONTACTOR
CA	COMFORT ALERT MODULE
CC	COMPRESSOR CONTACTOR
CCH	CRANKCASE HEATER
CFS	CLOGGED FILTER SWITCH
COMP	COMPRESSOR
CT	CONTROL TRANSFORMER
DAT	DISCHARGE AIR SENSOR
DISC	DISCONNECT SWITCH
FLMS	FLAME SENSOR
ECB	eSYNC CONTROL BOARD
ELM	ECONOMIZER LOGIC MODULE
FP	FAN PROVING
FS	FREEZE SENSOR
GFCO	GROUND FAULT CONVENIENCE OUTLET
GL	GROUND LUG
GND	GROUND
GV	GAS VALVE
HPC	HIGH PRESSURE CONTROL
HPT	HIGH PRESSURE TRANSDUCER
IBM	INDOOR BLOWER MOTOR
IBM	BELT DRIVE
IDM	INDUCED DRAFT MOTOR
IFC	INTEGRATED FURNACE CONTROL
LAC	LOW AMBIENT COOLING CONTROL
LC	LIMIT CONTROL
LLT	LIQUID LINE TEMPERATURE
LPC	LOW PRESSURE CONTROL
LPT	LOW PRESSURE TRANSDUCER
LS	LEAK SENSOR
MRLC	MANUAL RESET LIMIT CONTROL
NPC	NEGATIVE PRESSURE CONTROL
OAT	OUTSIDE AIR SENSOR
OFM	OUTDOOR FAN MOTOR
OFR	OUTDOOR FAN RELAY
PL	PLUG
PR	PUMP RELAY
PT	POWER TRANSFORMER
RAT	RETURN AIR SENSOR
RC	RUN CAPACITOR
RTU-C	ROOFTOP UNIT CONTROL
SE	SPARK ELECTRODE
TB	TERMINAL BLOCK
TWV	THREE-WAY VALVE
WFS	WATER FLOW SWITCH
WP	WATER PUMP
WS	WATER SOLENOID
WSR	WATER SHUTOFF RELAY
WT	WATER TEMPERATURE SENSOR
WN	WIRE NUT

WIRING INFORMATION	
LINE VOLTAGE	-FACTORY STANDARD
	-FACTORY OPTION
	-FIELD INSTALLED
LOW VOLTAGE	-FACTORY STANDARD
	-FACTORY OPTION
	-FIELD INSTALLED
REPLACEMENT WIRE	-MUST BE THE SAME SIZE AND TYPE OF INSULATION AS ORIGINAL (105° C MIN.)
WARNING	-CABINET MUST BE PERMANENTLY GROUNDED AND CONFORM TO I.E.C., N.E.C., C.E.C., AND LOCAL CODES AS APPLICABLE.

WIRE COLOR CODE			
BK	BLACK	O	ORANGE
BR	BROWN	PR	PURPLE
BL	BLUE	R	RED
G	GREEN	W	WHITE
GY	GRAY	Y	YELLOW

WIRING SCHEMATIC			
RKHL-D180			
208-230V 3 PH, 60 HZ.			
ROOFTOP W/RTU-C			
DR. BY	APP. BY	DATE	DWG. NO.
MGR		1-4-13	90-104655-01
			REV 00

BEFORE PURCHASING THIS APPLIANCE, READ IMPORTANT ENERGY COST AND EFFICIENCY INFORMATION AVAILABLE FROM YOUR RETAILER.

GENERAL TERMS OF LIMITED WARRANTY*

Rheem will furnish a replacement for any part of this product which fails in normal use and service within the applicable periods stated, in accordance with the terms of the limited warranty.

***For complete details of the Limited and Conditional Warranties, including applicable terms and conditions, contact your local contractor or the Manufacturer for a copy of the product warranty certificate.**

Compressor
 3 Phase, Commercial Applications.....Five (5) Years
Parts
 3 Phase, Commercial ApplicationsOne (1) Year
Heat Exchanger
 Factory, 3 Phase, Commercial Applications.....Ten (10) Years
 Stainless Steel, 3 Phase,
 Commercial ApplicationsTwenty (20) Years



The new degree of comfort.™

In keeping with its policy of continuous progress and product improvement, Rheem reserves the right to make changes without notice.

Rheem Heating, Cooling & Water Heating • P.O. Box 17010
Fort Smith, Arkansas 72917 • www.rheem.com

Rheem Canada Ltd./Ltée • 125 Edgeware Road, Unit 1
Brampton, Ontario • L6Y 0P5



INTEGRATED AIR & WATER