

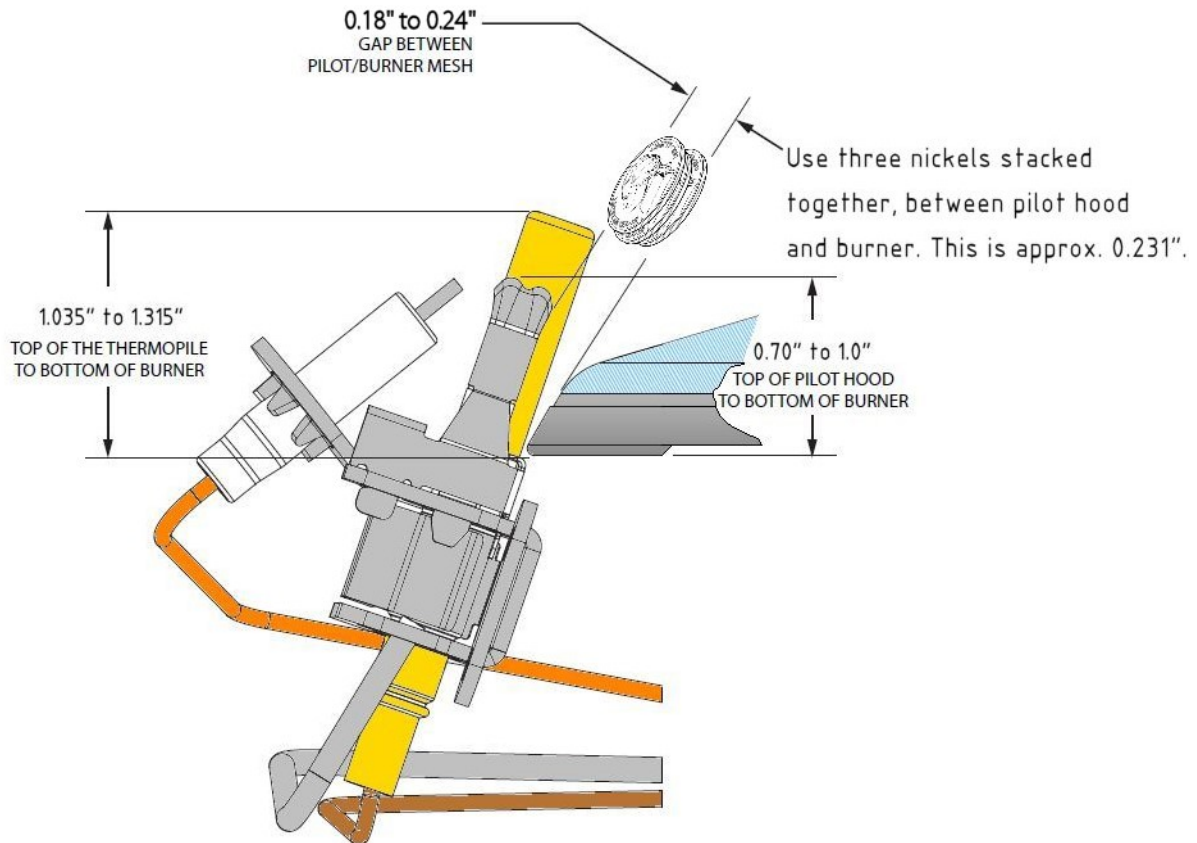

Proper Position for the Pilot Assembly for the ULN Residential Gas Atmospheric

Rheem has become aware that in limited production quantities, the ULN atmospheric models may experience pilot outages causing intermittent operation of the burner. If you experience this issue, please check pilot's position using the following information.



**Pilot Location Details**

The above picture illustrates the proper position for the pilot assembly for the ULN residential gas atmospheric heaters with mesh type radiant burner. Pilot assembly out of position can create problems of the water heater staying lit.



## Technical Service Department

Technical Service Bulletin

1-800-432-8373



---

### Proper Position for the Pilot Assembly for the ULN Residential Gas Atmospheric

Once the pilot is mounted, ensure the screws are tight and the spacing is correct. Ensure the pilot bracket assembly is also mounted securely.

- Just under a  $\frac{1}{4}$ " gap between pilot hood and burner mesh.  
\*(you can use 3 nickels, or 3 quarters.)
- Approximately  $\frac{7}{8}$ " top of pilot hood to bottom of burner.
- Approximately  $1 \frac{3}{16}$ " from top of thermopile to bottom of burner.

\*Note: Nickel has a thickness of 0.077". Quarter has thickness of 0.069".

After insuring the position of the pilot is to the correct gap dimensions, the ignition process can be followed per the instructions on the unit or in the Use & Care manual. Any gas valve error code related to the pilot position will clear and allow for proper burner operation.

If you have questions regarding this bulletin or have a unit experiencing this problem, call Rheem Technical Service (or Rheem Customer Service).

